

AB "AXIS INDUSTRIES"

ULTRASONIC HEAT METER SKU - 4



BASIC TECHNICAL DESCRIPTION

KAUNAS



SAFETY REQUIREMENTS

Before operating the meter, please read this technical description and user's manual thoroughly and follow their instructions.

- When the meter is powered from the battery (3.6 V), risk factors during the meter installation and service is a heat conveying fluid with inner pressure up to 1,6 MPa and temperature up to 180°C.
- If meter is powered from mains power supply, it contains dangerous ~230 V electrical current. It is necessary to follow general safety requirements during installation and maintenance process.
- To eliminate this risk, only qualified technical personnel may install and maintain heat meters (certificates for electrical installation work with equipment up to 1000 V are required). Personnel must be familiar with appropriate technical documentation and general safety instructions.
- Device comply with safety class II. and does not require protective grounding. To protect power circuits from current overrun, 0,1A fuse, marked "F1", is mounted on the bottom side of power supply module. Remove power supply module to replace the fuse.
If relay output current exceeds 2 A, it may damage output circuits. It is recommended to use additional protection circuits to protect relay outputs from damage.

Safety guarantees at installation and service of meter is:

- Reliable insulation of electrical circuits,
- Hermetic fitting of primary flow and temperature sensors into the pipeline,
- Reliable fastening of a sub-assemblies of heat meter at installation.

Safety requirements for temperature and pressure sensors are provided in appropriate technical documentation.

Warning! Switch off mains power supply before changing, repairing, connecting or disconnecting system parts, if meter is powered from mains power supply! Power switch has to be installed close to the calculator.

Mounting of the sub-assemblies of heat meter is permissible only after ensuring of absence of heat conveying fluid in the pipeline.

- **When the meter is powered from the mains supply 230 V:**

- The calculator of meter should be mounted in the cabinet (panel)
- The calculator of meter must be connected to line voltage 230 V using 3-wire copper cable with cross-section of each wire not less than 0,5 mm² (3x0, 5 mm²) with the color marking. External diameter of a cable must be 6 ... 8 mm.
- The meter must be connected to mains power supply only through automatic unipolar AC switch (nominal current 2 A) (Figure B3)..
- The automatic switch should be a part of the building wiring and it should be marked as disconnecting device of meter. The automatic switch should be installed close to meter and so that it was easily available to service personnel.

It is recommended to establish the calculator in the same cabinet as the switches for cutting off power supply. The switches should be adjusted for the power used by the equipment.

Caution: If this equipment is used in a manner not specified by the manufacturer, the protection provided by the equipment may be impaired.

Contents

	Psl.
1. Application field.....	3
2. Technical data.....	5
3. Accessories and sub-assemblies.....	12
4. Operating principle.....	12
5. Marking and sealing.....	13
6. Safety requirements.....	14
7. Installation.....	14
8. Operation	22
9. Verification.....	33
10. Transportation and storage.....	34
11. Warranty.....	34
12. Individual technical data.....	34
Annex A. Measurement schemes and energy calculation formulas	42
Annex B. Electrical wiring diagrams.....	45
Annex C. Numbering of terminals.....	47
Annex D. Outline and mounting dimensions of calculator.....	49
Annex E. Outline and mounting dimensions of ultrasonic flow sensors.....	51
Annex F. Outline and mounting dimensions of temperature sensors.....	

For EU Customers only - WEEE Marking.

Marking of electrical and electronic equipment in accordance with Article 11 (2) of Directive 2002/96/EC



This symbol on the product indicates that it will not be treated as household waste. It must be handed over to the applicable take-back scheme for the recycling of electrical and electronic equipment. For more detailed information about the recycling of this product, please contact your local municipal office.

1. APPLICATION FIELD

Ultrasonic heat meter SKU – 4 is designed for metering of consumed heating or cooling energy in closed heating/cooling systems, and consumed or supplied heating energy in closed heating systems, installed in dwelling houses, office buildings or energy plants.

Heat meter SKU-4 consists of the primary flow sensor and the calculator with type approved pair of temperature sensors with Pt500 elements.

The user may select (ordering the meter) one of twelve possible measurement schemes, according to the application type:

Available measurement schemes SKU – 4 – _____

Measurement scheme application	Conventional designation
For closed heating system with flow sensor in supply pipe	U1
For closed heating system with flow sensor in return pipe	U2
For closed heating system with flow sensor in supply pipe. With leakage detection option	U1F
For closed heating system with flow sensor in return pipe With leakage detection option	U2F
For closed system for accounting of heating - cooling energy with flow sensor in flow pipe	U1L
For closed system for accounting of heating - cooling energy with flow sensor in return pipe	U2L
For closed heating system with flow sensor in flow pipe or for open heating system with the cold water temperature measurement and with two flow sensors, installed in flow and return pipes	A*
For closed heating system with flow sensor in return pipe or for open heating system for accounting energy consumption for heating and hot water preparation with cold water temperature measurement and with two flow sensors, installed in flow and return pipes for accounting of supplied heat energy	A1*
For closed heating systems with flow sensor in return pipe or for open heating system with two flow sensors, installed in flow and replenishment pipes for accounting of supplied heat energy	A2*
For closed heating systems with flow sensor in return pipe or for open heating system with two flow sensors, installed in flow and replenishment pipes for accounting of supplied heat energy	A4*
For combined heating - hot-water preparing systems. Two independent heat meters: 1st - For closed heating system with flow sensor in flow pipe. 2nd -For accounting of hot water energy	U1A3**
For combined heating - hot-water preparing systems. Two independent heat meters: 1st - For closed heating system with flow sensor in return pipe. 2nd -For accounting of hot water energy	U2A3**

Remarks:

1* - The requirements of the Directive 2004/22/EC are applied only to these measurement schemes when the meter is used for measurement of thermal energy in the closed heating system. In that case when the meter is used for measurement of thermal energy in open heating system, it is a subject of Lithuanian national technical rules (“Rules on accounting of thermal energy and amount of heat-conveying liquid”, Official Gazette:1999, No 112-3270, in Lithuanian).

2. ** The requirements of the Directive 2004/22/EC are applied only to these measurement schemes then the meter intended for accounting of thermal energy in closed heating system. “Rules on

accounting of thermal energy and amount of heat-conveying liquid” are applied to the meter, which is intended for accounting hot water thermal energy.

3. Heat (cooling) energy calculation formulas for each measurement diagrams are presented in Annex A. Additional flow, temperature T3 and pressure measurement channels that are not used for heat energy measurement can be used to control other parameters.

Heat meter corresponds to essential requirements of the Technical Regulation for Measuring Instruments, dated 30 March 2006 (transposing in the NB’s country law Directive 2004/22/EC of 31 March 2004 on measuring instruments):

- Annex I Essential requirements
- Annex MI-004 Heat meter ,

SKU-4 complies with the European standard EN 1434 “Heat meters”.

SKU-4 fulfils “C” class environment protection requirements according to EN1434-1:2007

Climatic ambient temperature range: from 5 ° to 55 ° C

Humidity: non condensing

Location: closed

Mechanical environment class: M1

Electromagnetic environment class: E2

Type number combination of the heat meter SKU-4 for order placing:

SKU-4 - □□ - □ - □□ - □ - □□ - □□ - □□ - □□ - □□ - □

Type

Measurement scheme:

Conventional designation	Code	Conventional designation	Code	Conventional designation	Code
U1	01	U1L	06	A2	12
U2	02	U2L	07	A4	14
U1F	04	A	08	U1A3	16
U2F	05	A1	10	U2A3	17

Accuracy class:

Accuracy class	Code
2	2

Temperature sensors connectionscheme, temperature difference measurement range:

Temperature sensors connectionscheme	Code	Temperature sensors connectionscheme	Code
2-wire method, (2...150) K	22	2-wire method, (3...150) K	23
4-wire method, (2...150) K	42	4-wire method, (3...150) K	43

Power supply:

Power supply	Code
Bartery 3,6 V	1
Main power supply 230 V	2

Permanent flow rate q_p of sensor of 1st flow measurement channel:

q_p m ³ /h	Code	q_p m ³ /h	Code	q_p m ³ /h	Code
3,5	01	15	04	60	08
6	02	25	05		
10	03	40	06		

Permanent flow rate q_p of sensor of 2nd flow measurement channel:

q_p m ³ /h	Code	q_p m ³ /h	Code	q_p m ³ /h	Code
3,5	01	15	04	60	08
6	02	25	05		
10	03	40	06		

Connection cable length of flow sensors, m:

Lenght	Code	Lenght	Code	Lenght	Code	Lenght	Code	Lenght	Code
3 m	01	10 m	03	20 m	05	60 m	07	100 m	09
5 m	02	15 m	04	40 m	06	80 m	08	None	00

Connection cable length of temperature sensors, m:

Lenght	Code	Lenght	Code	Lenght	Code	Lenght	Code	Lenght	Code
3 m	01	10 m	03	20 m	05	60 m	07	100 m	09
5 m	02	15 m	04	40 m	06	80 m	08	None	00

Communication interface:

Type	Code	Type	Code
None	0	M-bus/RS232/CL , current output	4
M-bus	1	M-bus/RS232/CL , pulse output	5
RS232	2		
RS485	3		

2. TECHNICAL DATA

2.1. Energy measurement

2.1.1. Accuracy class - 2

Maximum permissible heat energy measurement error of calculator and flow sensor:

$$E = \pm(2,5 + \Delta\Theta_{\min} / \Delta\Theta + 0,02q_p / q), \%$$

Maximum permissible heat energy measurement error of complete meter (error of temperature sensors pair included):

$$E = \pm(3+4 \Delta\Theta_{\min} / \Delta\Theta + 0,02q_p / q)$$

- where: $\Delta\Theta_{\min}$ - lower limit of the temperature difference, K;
 $\Delta\Theta$ - temperature difference, between the measured flow and return temperatures of heat-conveying liquid K;
 q_p - permanent flow-rate, m³/h ;
 q - measured flow-rate, m³/h .

2.1.2. Thermal energy calculation

Consumed heat energy is calculated according to formulas given in Annex A

It is possible to perform calculations in two ways, using programmed or practically measured pressure values (1-st pressure channel corresponds to the flow pipe, 2-nd – return pipe);

Possible heat energy measurement algorithms (selected in configuration mode):

- Standard: Unidirectional flow measurement, energy is calculated without any restrictions,
- Special: Unidirectional flow measurement,

Energy and quantity of liquid are not calculated in those cases:

- flow rate exceeds programmed maximum allowed value
- flow rate is under programmed minimum allowed value
- or temperature difference is under programmed minimum allowed value

Error code is generated when parameter values exceed given limits. Also, in that case the device intermit calculating working time, and calculates error duration.

- Winter / summer: Flow in 2-nd channel is measured in both directions, energy is calculated taking into account flow direction without any limitations (only for A and A1 measurement circuits – see Table 1).

2.1.3. Maximum power value

64 MW

2.2. Temperature measurement

- Number of sensor inputs (measurement channels) 1, 2 or 3*
- Temperature sensors type Pt500
- Absolute temperature Θ measurement error not more than $\pm 0,3$ °C
- Sensor connection method ** 2-wire, 4-wire
- Max. cable length between calculator and each of the temperature sensors:
 - for the 4-wire connection method 3; 5; 10; 15; 20; 40; 60; 80; 100 m,
 - for the 2-wire connection method 3; 5 m,
- Temperature measuring range (Θ_1 ... Θ_3) 0...180 °C
- Temperature displaying range (Θ_3) -40...180 °C
- Temperature difference (Θ_1 - Θ_2)

measuring range 2...150 °C (or 3...150 °C)***
 - Resolution of temperatures and temperature difference 0,1 °C

NOTES: * - additional 3rd channel selects the user during on-site installation
 ** - selected by the customer when ordering the device
 *** - depending on the value of the lower measurement limit of the temperature difference of the connected pair of temperature sensors

- Recorded errors and their duration $\Theta > 181$ °C (or open circuit),
 $\Theta < -41$ °C (or short-circuit),

2.3. Flow measurement

2.3.1. Ultrasonic flow measurement channels (sensors) 1 and 2

- Ultrasonic flow measurement sensors
 (depending on the measurement circuits) 2 or 1

Heat meter flow sensor data are presented in Table 2.1

Table 2.1

Connection type	Flow-rate, m ³ /h			Overall length, mm	Pressure loss Δp , at q_p , kPa, not more than
	q_i^*	q_p	q_s		
Thread G 1¼	0,035 (0,14)	3,5	7,0	260	4
Thread G 1¼	0,06 (0,25)	6,0	12,0	260	10
Thread G 2	0,1 (0,4)	10,0	20,0	300	10
Flange DN50	0,15 (0,6)	15,0	30,0	270	12
DN65	0,25 (1)	25,0	50,0	300	20
DN80	0,4 (1,6)	40,0	80,0	350	18
DN100	0,6 (2,4)	60,0	120,0	350	18

Remark:

1. *Values of the minimum flow rates for measurement schemes U1L and U2L (accounting of heating-cooling energy) are presented in brackets.

Temperature limits of heat conveying liquid:

$\Theta_q = 10...130$ °C (to all measurement schemes, except U1L and U2L);

$\Theta_q = 0...130$ °C (to measurement schemes U1L and U2L, intended for the account of energy for heating and cooling);

Accuracy class - 2

Limits of a permissible error of volume (mass) measurement:

$$E_f = \pm (2 + 0,02q_p/q), \%$$

- Difference of measurement errors of the pair flow sensors in flow range from 0.1 q_p to q_s

(for circuits U1F, U2F, A1)

no more than $\pm 1,0$ %.

Function of flow measurement in two directions is provided

- Connection line length between the calculator and each of the flow sensor

3; 5; 10; 15; 20; 40; 60; 80; 100 m,

- Recorded errors and their duration:

- the flow channel is broken,
- the pipe is empty,
- flow rate exceeds maximum allowed value,

- flow rate is under minimum allowed value,
- measurement units m^3 or t ;
- threshold value $0,001*qp$

2.3.2. Flow pulse input (3 and 4)

- number of pulse inputs 2
- pulse values programmable
- type of pulses active, passive
- high voltage ranges of active pulses 2,5...3,7V
- low voltage ranges of active pulses 0 ...0,7V
- input resistance* at the battery supply 2 MOm
- input resistance* at the main supply 10 kOm
- (*Resistance of internal resistor to 3.6 V circuit)
- integrated programmable filter: programmatically rejected input pulses, where the repetition period is less than the stated period of the filter (2...999 ms)
- communication cable length between calculator and each of the sensors 3; 5; 10; 15; 20; 40; 60; 80; 100 m,
- recorded errors and error duration(depending on the configuration):
 - none recorded
 - recorded at short circuit on line (or an impulse low level) longer than 2 s
 - recorded when flow rate exceeds programmed maximum allowed value
 - recorded when flow rate is under programmed minimum allowed value
 - recorded when the pulse is not more than 24 hours.
- display units m^3
- maximum permissible input pulse frequency and minimal permissible pulse or pause duration, depending on pulse type and cable length:

Table 2.2

Power supply of meter/ Flow pulse input type	Connection cable length , m	Maximum permissible pulse frequency, Hz	Minimal permissible pulse or pause duration, ms
Mains supply / Active or passive pulses (transistor key or mechanical contact)	≤ 100 m	200	2,5
Battery supply/ Passive pulses (transistor key or mechanical contact)	≤ 10 m	5	100

- Flow rate value (for information) is calculated:

- when the flow input pulse duration period is $T < 10$ s - each 10 s as multiplication of flow pulse value and flow pulse average period,
- when the flow input pulse duration period is $T = 10...180$ s - flow input pulse duration periodicity as multiplication of flow pulse value and flow pulse period,
- when the flow input pulse duration period is $T > 180$ s - the value zero is indicated.

2.4. Pressure measurement

- Number of pressure inputs 0...2

- Display units	kPa
- Fiducial error	not more than $\pm 0,25$ % of the upper limit of the measurement range
Pressure measurement ranges:	
- lower limit , programmable	from 0 kPa to 2500 kPa
- upper limit, programmable	from 100 kPa to 2500 kPa
Normalized input dimension	current, linearly dependent on the pressure
- input current limits, programmable	0-5 mA, 0-20 mA, 4-20 mA
- input resistance	110 Ω

2.5. Time measurement

Relative time measurement error	not more than $\pm 0,01$ %
Heat meter calculator measures:	
- real time - calendar	
- time, when device is powered on	
- normal working hours	
- failure time of additional flow sensors V3 .. V4	
- time, when flow rate exceeds programmed maximum allowed value for channels V3...V4	
- time, when flow rate is under programmed minimum allowed value for channels V3...V4	
- time, when temperature difference $\Theta_1-\Theta_2$ is under programmed minimum allowed value	
Display resolution:	
• the real time display	1 s
• for operating time display	0,01 h
Time of storage date	not less than 12 years

2.6. Display (LCD)

The device is equipped with 8-digits LCD (Liquid Crystal Display) with special symbols to display parameters, measurement units and operation modes

The following information can be displayed:

- integral and instantaneous measured parameters and archive data, listed in the Table 2.4.
- device configuration information (see Fig. 8.2.6).
- report printing control information (see Fig.8.2.5).

Display resolution (directly corresponding with pulse output value), depending on programmed maximum flow rate value (the highest value of the flow channel, involved in the energy calculation formula), is provided in the Table 2.3

Table 2.3

Maximum programmed flow rate, m^3/h	Displayed fluid volume (mass) lowest digit value (flow pulse output value), m^3	Displayed energy lowest digit value (energy pulse output value), MWh, Gcal, GJ
$q_s < 5$	0,001	0,0001
$5 \leq q_s < 50$	0,01	0,001
$50 \leq q_s < 500$	0,1	0,01
$500 \leq q_s$	1	-

2.7. Measured and recorded parameters:

Table 2.4

Arbitrary symbol	Parameter	Display capacity,	Recorded in
------------------	-----------	-------------------	-------------

		measurement units, measurement ranges	archive
Integral parameters			
ΣE	Total consumed energy (in accordance with Annex A)	8 digits, MWh, Gcal, GJ*	Absolute values every hour, alterations every hour, day and month
E1	1 st component of energy (in accordance with Annex A)		
E2	2 nd component of energy (in accordance with Annex A)		
V1(M1)	Fluid volume (mass) of 1-st measurement channel	8 digits, m ³ (t)	
V2 (M2)	Fluid volume (mass) of 2-nd measurement channel		
-M2	Reverse flow fluid mass in 2-nd channel (only for "winter / summer" algorithm)	8 digits, m ³ (t)	
M1-M2 (V1-V2)	Fluid volume (mass) difference between 1-st and 2-nd measurement channels	8 digits, m ³ (t)	
V3 (M3)	Fluid volume (mass) of 3-rd measurement channel	8 digits, m ³	
V4	Fluid volume of 4-th measurement channel		
	Total operation time	8 digits, 0,01 h	
A	Operation time in normal mode		
Er ₁	Codes of significant faults (errors)	6 digits	Amount in hour, day, month
Er ₂	Codes of transitory faults (errors)	6 digits	
Instantaneous parameters			
P	Total instantaneous thermal power	5 digits, kW	-----
q1	Flow rate on 1-st channel	5 digits, m ³ /h a rba t /h	-----
q2	Flow rate on 2-nd channel		
q3	Flow rate on 3-rd channel		
q4	Flow rate on 4-th channel	5 digits, m ³ /h	
p1	1-st channel fluid pressure	0 ... 2500,0 kPa	Average hourly, daily and monthly data
p2	2-nd channel fluid pressure		
Θ1	1-st channel fluid temperature	0...180 °C	
Θ2	2-nd channel fluid temperature		
Θ1-Θ2	1-st and 2-nd channel temperature difference		
Θ3	3-rd channel fluid temperature	- 40...+180 °C	

2.8. Data recording and storage

Following daily, weekly and monthly parameter values are recorded in heat meter memory:

- absolute integral instantaneous parameter values (listed in Table 2.4)
- hourly, weekly and monthly alterations of integral parameters
- hourly, weekly and monthly average values for all measured temperature and pressure values
- error (fault) and information codes (see paragraph. 8.2.2) that occurred during the last hour, day and month

Data logger capacity:

up to 110 days (3,5 months) – for hourly records.

up to 1024 days (33 last months) -. for daily and monthly records,

Archive data retention time

not more than 33 months

Retention time of measured integrated parameters

even if device is disconnected from power supply not more than 12 years

2.9. External communication modules and interfaces

2.9.1. Optical interface according to EN 62056-21:2003 (integrated into the front panel)

Optical interface is designed for:

- read out of values by protocol EN IEC 62056 or M-bus
- direct printing reports (by ASCII codes)
- read out archive data by protocol M-bus
- configuring of the meter by means of the special protocol (parameterization mode is actuated by button "SET")
- adjusting of the meter by means of the special protocol (adjusting mode is actuated by jumper)

Programmable data transfer rate (300 ... 9600) bps
with the "Even" parity or not.

2.9.2. Wire communication interfaces (as optional plug in modules)

- M-bus (according to EN1434-3);
- M-bus / CL / RS232 / two pulses outputs;
- M-bus /CL / RS232 / two current outputs;
- RS232,
- R485.

Wire communication interface protocol

M-bus (according to EN1434-3)

Data transfer rate

Programmable (300 ... 9600) bps
with the "Even" parity or not.

2.9.2. Pulse -frequency and current outputs

Two programmable (configurable) pulse or frequency (available only with mains power supply version) outputs (as optional plug-in module)

Pulse outputs type (the user can select):

“Open collector”
or 24 V active pulses

Two programmable current outputs (as optional plug-in module, only available with mains power supply version):

0-20mA
or 4-20mA

The configurable pulse-frequency output in “pulse mode” can be used for thermal energy (ΣE , E1, E2, E3) or quantity of liquid V1 (M1), V2(M2), V3(M3), V4 pulses Pulse value will correspond to the lowest digit of indicated parameter.

The configurable pulse-frequency output in “frequency mode” or current output can be used for thermal power, flow rate (q_1, q_2, q_3, q_4), temperature ($\Theta_1, \Theta_2, \Theta_3$) or pressure (p_1, p_2) pulses.

Zero value of frequency (or the minimum value of the selected range of a current) corresponds to zero value of an output parameter, and frequency 1000 Hz (or maximum value of the selected range of a current) corresponds to maximum value of parameter:

flow rate – q_{\max} ,

temperature – 180 °C,

pressure – p_{\max} ,

thermal power – $q_{\max} * 100$ [kW],

There q_{\max} - the maximum flow rate in the measurement channel [m^3/h]).

2.10. Additional functions

2.10.1. Regulation function

Available only with mains power supply version. The double relay output (230V) is intended for controlling of current load up to 2A and it is fitted in main supply module.

Using electrically-controlled valve gives the possibility:

- automatically maintain selected parameter value within defined limits,
- prevent selected parameter from exceeding maximum allowed value,
- prevent selected parameter from falling below minimal allowed value
- control a water temperature on the flow pipeline, to maintain the preset room temperature, depending on outdoor temperature (Θ_3).

Following parameters can be selected for regulation:

- thermal power,
- any flow ($q_1 \dots q_4$),
- any temperature ($\Theta_1 \dots \Theta_3$),
- temperature difference ($\Theta_1 - \Theta_2$),
- any pressure (p_1 or p_2).

! IMPORTANT: Regulation will be efficient only if regulated valve is installed in such way that it can effect regulated parameter.

Regulation speed (time interval from fully opening the valve to fully closing the valve) is programmable.

Following electrically-controlled valves may be used for regulation:

- with separate control inputs for opening and closing the valve,
- where current required to open or close the valve does not exceed 2A,
- where voltage required to open or close the valve does not exceed 230 V

2.11. Alarm function

If regulation function is not required, relay output can be used to generate alarm signal. Relay contacts will close, if:

- selected parameter value exceeds measurement limits,
- selected parameter exceeds maximum allowed value,
- selected parameter falls below minimum allowed value.

Any parameter listed in paragraph 2.10.1 can be used to generate alarm signal.

2.12. Supply voltage

Internal battery*

3,6 VDC, D-cell lithium

Replacement interval not less than 10 years,

Mains supply

AC (50±2) Hz, 230 V $\begin{matrix} +10 \\ -15 \end{matrix}$ %,

Power supply < 3 VA (only for meter)

Power supply < 15 VA

(for meter and extra sensors)

Power supply for extra sensors

Voltage for powering pressure or extra flow sensors $+18 \text{ V} \pm 10 \%$
(only for meter with mains supply module) total current < 400 mA.

Voltage for powering extra flow sensors $+3,6 \text{ V} \pm 10 \%$,
(only for meter with mains supply module) total current < 20 mA.

Voltage for powering extra ultrasonic flow sensors $+3,6 \text{ V} \pm 10 \%$,
(for meter with supply from battery) total current < 70 mA.

NOTE: *

Functional limitations, when the meter is powered from internal batteries:
1. It is impossible to use relay regulator/alarm outputs function
2. It is impossible to use frequency and current outputs function
3. Unavailable pressure sensor power supply from the meter
5. Automatic restriction of operating time of communication interface (wire and optical) till 80 minutes per month

2.13. Mechanical data

Dimensions of calculator	159 mm x 52 mm x 142 mm
Dimensions of flow sensors	According to Annex H
Weight of calculator	0,5 kg.
Weight of flow sensors	According to table 2.7

Table 2.7

Permanent flow rate in m ³ /h (connection type)	Mass*, not more than, kg
3,5 (G1 ¼ B)	3,0
6 (G1 ¼ B)	3,0
10 (G2 B)	4,0
15 (DN50)	10,0
25 (DN65)	13,0
40 (DN80)	15,0
60 (DN100)	18,0

NOTE: The mass of flow sensor is presented without mass of connecting cables. Maximum mass of cables is 8 kg (2x100 m)

Environmental class	Meets EN1434 class C
Ambient temperature: Calculator	at +5 °C to +55 °C (non-condensing, indoor installation)
Floe sensors	at -30 °C to 55 °C
Relative humidity	< 93 %
Mechanical environment class:	M1
Electromagnetic environment class:	E2
Protection class of calculator enclosure	IP65
Protection class of flow sensor enclosure	IP65 (IP67 – by special ordering)

3. ACCESSORIES AND SUB-ASSEMBLIES OF HEAT METER

Required sub-assemblies and accessories may be delivered according to the particular application and flow measurement scheme, as defined by the customer (listed in Table 3.1):

Table 3.1

Item	Amount, pcs
1. Heat meter calculator SKU-4	1
2. Technical description, user manual for heat meter SKU-4	1
3. Mounting kit for heat meter calculator	1*
4. Ultrasonic flow sensors	1...2*
5. Internal battery 3,6 V	1*

6. Internal 230 V mains power supply module	1*
7. Communication module SKS43 with M-bus interface	1*
8. Communication module SKU45 with M-bus, CL, RS-232 interfaces and two current outputs	1*
9. Communication module SKU46 with M-bus, CL, RS-232 interfaces and two pulse outputs	1*
10. Communication module SKSRS485 with RS-485 interface	1*
11. Communication module SKS48Y with special interface for connection to the controller Rubisafe-P01	1*
12. Communication module SKS48 with special interface, compatible with RS-232	1*
13. Temperature sensors PL-6, Pt500 (two wire connection method)	1...3*
14. User manual for temperature sensors type PL-6	1*
15. Pressure sensors MBS	2*

REMARKS: 1. “*” – required options selected by the customer,
2. Heat meter may be equipped with other types of temperature sensors, if they correspond to requirements listed in paragraph 2, requirements of EN1434 standard and have the EC-type examination certificate by Directive 2004/22/EC
3. Heat meter may be equipped with other types of pressure sensors, if they correspond to requirements listed in paragraph 2, are included in Lithuanian state registry of measurement equipment and have type approval certificate.

4. OPERATING PRINCIPLE

Ultrasonic heat and water meters SKU-4 is multichannel programmable microprocessor measuring device which consists of electronic unit (calculator) and the initial flow (up to 2), temperature (up to 3) and pressure (up to 2) sensors..

The flow measuring principle is based on ultrasonic measurement method. Fluid volume is calculated according the formula:

$$V = K_H * K_M * (1/t_+ - 1/t_-) * T ,$$

where: V - measured fluid volume, m³;

T – time of integration, s;

t₊ - measured upstream time of flight of ultrasonic pulse, s;

t₋ - measured downstream time of flight of ultrasonic pulse, s;

K_H – hydrodynamic correction factor;

K_M –coefficient that depends on the flow sensor dimensions.

The liquid temperature is measured with standard platinum resistance temperature sensors Pt500 or Pt1000. Pairs of temperature sensors with 2-wire or 4-wire connection method for measurement temperatures on flow and return pipelines are used. Flow and return temperature sensors can be replaced only in pairs.

The temperature sensor T3 (if not used for calculation of thermal energy) the user can activate and use for other technological measurements or for regulation function.

Thermal energy is calculated using formulas provided in Annex A.

Additional inputs of flow V3, V4 and pressure sensors, which are not used for thermal energy measurement, can be used (or not), for the control of other parameters.

Values of the measured and calculated parameters are shown on the display.

Possible thermal energy measurement algorithms are described in p. 2.2.2.

5. Marking and sealing

5.1. Marking of meter

Marking of calculator:

There are following information on the front panel of calculator - manufacturer's trade mark , identity marking (type designation and type number), serial number, year of manufacture, EC-type examination certificate number, limits of the temperature, limits of the heat conveying temperature, limits of the temperature differences, type of temperature sensors (Pt500), the limiting values of the flow rate (q_i, q_p, q_s), flow sensor installation site (flow or return pipe), accuracy class, environmental class by LST EN1434-1, electromagnetic and mechanical environmental class, enclosure protection class, the maximum admissible working pressure (PN class), voltage level for external power supply, conventional designation of the applied measurement scheme.

Numbers of terminal pins are marked close to the terminal

Marking of flow sensor:

There are following information on the flow sensor- manufacturer's trade mark , nominal diameter year of manufacture, serial number, arrow indicating the direction of the flow.

5.2. Security seals:

Manufacturer seals:

- One warranty seal (the adhesive seal-sticker) on the one fixing bolt of electronic module under protective cover (see Fig.8.1), .
- Seals on the screws of protective cover of flow sensor (Sticker or hanging seal according Annex E, Fig. E1..E6).

Calibration (verification) seal:

- One seal on the one bolt of protective cover of electronic module inside the calculator (see Fig.8.1).
- Seals on the screws of protective cover of flow sensor (Sticker or hanging seal according Annex E, Fig. E1..E6).

Mounting seal:

- One or two hanged seals on the fixers of junction of the top and bottom part of the calculator (see Annex D, Fig.D4...D5)
- Seals on the protective cover and mounting bolt of temperature sensors (see Annex F, Fig.1...2).

6. SAFETY REQUIREMENTS

When the meter is powered from the battery (3.6 V), risk factors during the meter installation and service is a heat conveying fluid flowing within flow sensor with inner pressure up to 1,6 MPa and temperature up to 180°C.

If meter is powered from mains power supply, it contains dangerous ~230 V electrical current.

To eliminate this risk, only qualified technical personnel may install and maintain heat meters (certificates for electrical installation work with equipment up to 1000 V are required). Personnel must be familiar with appropriate technical documentation and general safety instructions.

It is necessary to follow general safety requirements during installation and maintenance process.

Protective grounding is not required, because housing is made from plastics, and conductive parts are not exposed to the surface.

To protect power circuits from current overrun, 0,1A fuse, marked "F1", is mounted on the bottom side of power supply module. Remove power supply module to replace the fuse.

If relay output current exceeds 2 A, it may damage output circuits. It is recommended to use additional protection circuits to protect relay outputs from damage.

Safety guarantees at installation and service of meter is:

- Reliable insulation of electrical circuits,
- Hermetic fitting of primary flow and temperature sensors into the pipeline,
- Reliable fastening of a sub-assemblies of heat meter at installation.

Safety requirements for temperature and pressure sensors are provided in appropriate technical documentation.

Warning! Switch off mains power supply before changing, repairing, connecting or disconnecting system parts, if meter is powered from mains power supply! Power switch has to be installed close to the calculator.

Mounting of the sub-assemblies of heat meter is permissible only after ensuring of absence of heat conveying fluid in the pipeline.

7. INSTALLATION

Basic requirements

Before installing the device:

- check if all parts listed in the documentation are available,
- check if there are no visible mechanical defects,
- check if there are valid labels of manufacturer and certification authority.

Only qualified personnel may install the equipment, following the requirements listed in this document, in technical documentation of other system components and in heat meter installation project

Mechanical mounting

Mounting of calculator

Heat meter calculator may be installed in heated premises, on vertical surface. It may not be exposed to direct sunlight. Outline and mounting dimensions are provided in Annex D

Calculator can be mounted in five different ways:

- Wall mounting, without possibility sealing of mounting
- Wall mounting, with possibility sealing of mounting
- Mounting on standard DIN-rail
- Panel mounting
- Direct mounting on ultrasonic flow sensor

Note: For water heating temperatures above 90 °C, the calculator must be mounted on the wall.

Mounting of ultrasonic flow sensors

Outline and mounting dimensions of ultrasonic flow sensors are provided in Annex E.

Requirements for flow sensor installation in pipeline:

- For flow sensors with permanent flow rate $q_p = 3,5 \text{ m}^3/\text{h}$ and $q_p = 6 \text{ m}^3/\text{h}$:
 - no requirements for straight pipeline length in upstream and downstream directions.
- For flow sensors with permanent flow rate $q_p > 6 \text{ m}^3/\text{h}$:
 - upstream straight pipeline length must be not less 5DN and downstream straight pipeline length must be not less 3DN when flow disturbance is elbow type (1 or 2 elbows);
 - upstream straight pipeline length must be not less 10DN and downstream straight pipeline length must be not less 3DN when flow disturbance is valve, pump or similar disturber;

Avoid the flow sensor installation near after the pumps which can cause cavitations.

Flow sensor can be mounted both vertically and horizontally in pipelines. Vertically mounting of the flowmeter is allowed only if flow direction in the pipeline is from down to up.

The direction of the sensor installation (is indicated with the arrow on the label of flow sensor) must match with the flow direction in pipeline.

The flange gaskets must match with the pipe diameter. During the installation gasket must be exactly centered with the center of the pipe cross-section to avoid sticking out gaskets inside the pipe.

Mounting of temperature sensors

Temperature sensors are mounted by head upwards, is perpendicular to the pipe axis or inclined by 45 ° angle on fluid flow direction so that the sensing element has been inserted in medium at least up to the pipe axis or beyond (as shown in Annex F).

Electrical wiring

Electrical installation of heat meter is performed according to selected measurement scheme (Annex B) and appropriate installation diagrams (Annex B), also according to technical requirements for other system components. Description of connection terminal pins is provided in Annex C.

The signal wires can be connected to the calculator only after full installation of the meter.

It is forbidden to change length of a cable.

Temperature sensor connection:

2-wire or 4-wire connections could be used.

Using 4-wire connection schemes – the connection must be performed with the grounded cables with signal wires with the cross-section not less than 0.12 mm².

Using 2-wire connection schemes - the connection must be performed with the grounded cables with total resistance of signal wires not more than 0.5 Ω and the cable length difference no more than 2 %

Before installation check that the temperature sensors are paired with each other (T1 to T2).



If cable length between calculation unit and sensors exceeds 5 m, shielded cables have to be used. Cables should be run through rubber seal caps and anchored with clamps. Four-, three- or two-wire cable should be used respectively. Cable shield should be connected to appropriate terminal pins (see diagram in Annex B) or to any free contacts marked with symbol “ \perp ” or is clamped with metal clips in an installation time.

At connection with the grounded cables it is necessary in addition one of free contacts „ \perp ” to connect to a contour of grounding of a building a copper wire with section (0,5... 1,0) mm².

It is forbidden to wire signal cables nearby (less than 5 cm) with power cables or cables of other devices.

7.2. Setting up the configuration



The heat meter is universal device for measurement of supplied (consumed) heating energy. The calculator has to be customized for the particular application, putting into account the type of heating system, also types of flow, temperature and pressure sensors. After placing an order, calculating unit is adapted to one of several possible measurement circuits. Energy calculation formulas and measurement circuits are presented in Annex A. Flow, temperature and pressure channels, unused for heat energy measurement, can be used to control other parameters. It is possible to select measurement units for flow measurement (volume units or mass units – according to measured media temperature).





The heat meter has to be programmed for the specific application using the control buttons  , also the configuration button “SET” (under the lid, see Fig. 8.1) or with the PC.

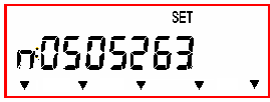
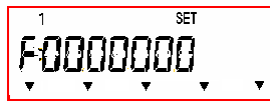
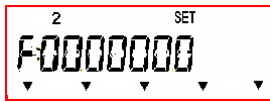

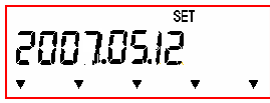
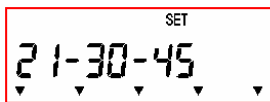
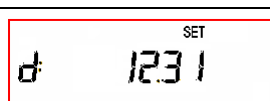
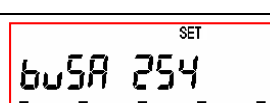
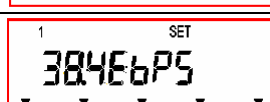
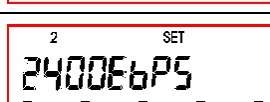
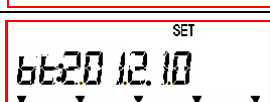
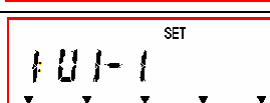
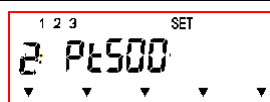
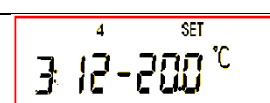

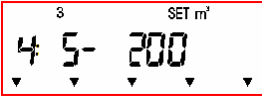
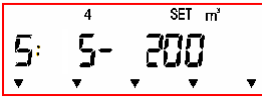
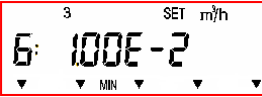
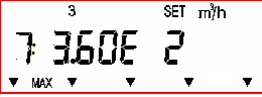
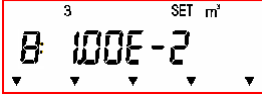
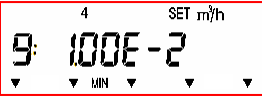
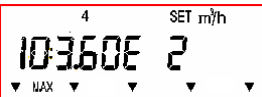
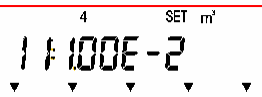
To enter the configuration mode, open the calculator lid and press the button “SET”. Press the “SET” button once more to leave the programming mode.

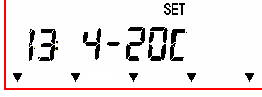
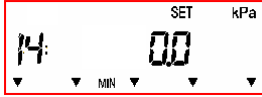
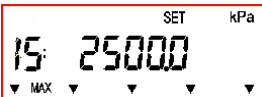
When configuration (programming) mode is active, label “SET” is displayed in the upper right corner of the display. All parameters have to be programmed. The algorithm for setting up parameters, possible parameter limits and abbreviations are listed in Table 7.1.

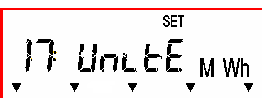
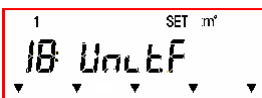
Table 7.1

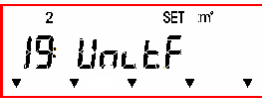
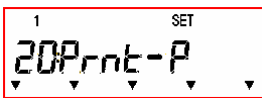
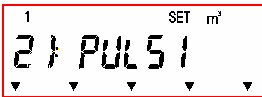
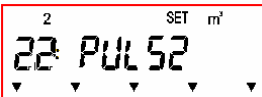
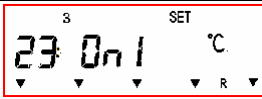
Menu description	LC Display example	Value (Possible limits of change)
Serial number of meter *		
Serial flow sensor number of 1 st flow measurement channel*		
Serial flow sensor number of 2 nd flow measurement channel*		
Customer number		0...999999
Real time calendar		The date format is <year>.<month>.<day >
Real time clock		The time format is: <hour>-<minute>-<second>
Set day		The yearly set day format is: 12.31 (<month>.<day>), The monthly set day format is: --.30 (<day>) -- . -- - function is deactivated
Serial communication interface address		0...255
Data transfer rate via wired interface		(300...38400, 300E...38400E) bytes/s “E” –parity “Even” None “E” – no parity
Data transfer rate via optical interface		(300...9600, 300E...9600E) bitu/s “E” –parity “Even” None “E” – no parity
Next replacement date of the battery		The date format is <year>.<month>)
Measuring circuit symbol and energy calculation algorithm*		U1,U2,U3,U1F,U2F,U1L,U2L,A,AC,A1, A1C,A2...A5,U1A3,U2A3,F1,F2 Algorithm: 1 –standard 2 – special 3 - “winter/summer”
List of active temprature sensors (“1 2 3”) and type of sensors*		Possible types: Pt500, Pt1000, 500II, 1000II
Month number and to it corresponding established value of cold water temperature constant		1...12, “-”-“(month number from 1 to 12); 0...99,9 °C For example: 12 month, Θ4 =20,0 °C (when „-“, - value Θ4 is valid for all months)

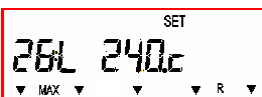
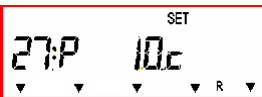
Type of 3-rd flow input (or OFF), minimal pulse period in ms, flow measurement units m ³ (or t)		Flow input type: S-standard, E – with error control; L – with the "24 hour" pulse control; OFF – flow input not used
Type of 4-th flow input (or OFF), minimal pulse period in ms, flow measurement units m ³ (or t)		Flow input type: S-standard, E – with error control; L – with the "24 hour" pulse control; OFF – flow input not used
Minimum flow rate value of 3-rd flow input, m ³ /h		Exponential form X.XXE-X For example: 1,00E-2 = 1,00*10 ⁻² = 0,01 m ³ /h
Maximum flow rate value of 3-rd flow input, m ³ /h		Exponential form X.XXE X For example: 3,60E2 = 3,60*10 ² = 360 m ³ /h
3-rd flow input pulse value, m ³ /pulse		Exponential form X.XXE-X For example: 1,00E-2 = 1,00*10 ⁻² = 0,01 m ³ /pulse
Minimum flow rate value of 4-th flow input, m ³ /h		Exponential form X.XXE-X For example: 1,00E-2 = 1,00*10 ⁻² = 0,01 m ³ /h
Maximum flow rate value of 4-th flow input, m ³ /h		Exponential form X.XXE X For example: 3,60E2 = 3,60*10 ² = 360 m ³ /h
4-th flow input pulse value, m ³ /pulse		Exponential form X.XXE-X For example: 1,00E-2 = 1,00*10 ⁻² = 0,01 m ³ /pulse
Minimum value of temperature difference Θ1 - Θ2		
Current limits of pressure sensors (pressure inputs)		pre-programmed pressure value: 0-20C – corresponding 0...20 mA, 4-20C - corresponding 4...20 mA, 0-5C - corresponding 0...5 mA, OFF – pressure sensors not used
Minimum rated value of pressure sensors, kPa		(0,0...25000) kPa
Maximum rated value of pressure sensors, kPa		(0,0...25000) kPa
The pressure value used in calculations of heat *, kPa		(0,0...9999,9) kPa If specify "0.0 kPa" - for calculation is used the measured pressure value (p1 – for flow pipe , p2–for return pipe)
Thermal energy units *		MWh (kWh), Gcal ar GJ
Measurement units of quantity of a liquid of 1-th flow measurement channel		For choice: m ³ or t

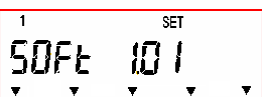
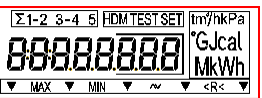
Measurement units of quantity of a liquid of 2-nd flow measurement channel		For choice: m ³ or t
Report printing language and communication with the printer interface type		Report language: Prnt-P –Russian, Prnt-L – Lithuanian, Prnt-E –English. Communication with the printer interface type: 1-wire interface, 2-optical interface
Parameter, derivable to 1 st pulse frequency output		MWh –thermal energy, m ³ - flow rate, kW-thermal power, °C –temperature, kPa-pressure, 1...4 -number of measurement channel, 1-2 difference
Parameter, derivable to 2 nd pulse frequency output		MWh –thermal energy, m ³ - flow rate, kW-thermal power, °C –temperature, kPa-pressure, 1...4 -number of measurement channel, 1-2 difference
Regulation function and settings of regulable (controlled) parameter		OFF – regulation function is disabled, On1 or On2 – type of active operating mode, Regulable parameter: kW-power, °C – temperature, m ³ /h –flow rate, kPa-pressure. 1...3 – number of channel.
Mode On1 -lower limit (the minimum allowed value) for regulated parameter. Mode On2 - preset room temperature		kW –power, m ³ /h-flow rate, °C –temperature, kPa –pressure. 1...4 - number of measurement channel. 1-2 –difference
Mode On1 - upper limit (the maximum allowed value) for regulated parameter Mode On2 - adaptation coefficient		kW –power, m ³ /h-flow rate, °C –temperature, kPa –pressure. 1...4 - number of measurement channel. 1-2 –difference
Valve runtime, s		0...999 s
Pause between actuation period (actuation period is equivalent to 1% of the preset valves runtime, s		0...999 s
Keeping the accuracy of preset flow temperature (hysteresis), °C (only for mode On2)		°C
the maximum allowed value of flow temperature (threshold value of protection), °C (only for mode On2)		°C
Software version number*		
LCD segment test*		

NOTES:

- The displayed parameters list can be shorter depending on the selected modification, and a meter configuration (parameters, inappropriate for the given configuration will not be shown).

2. Marked with "*" parameters values can be modified only by the manufacturer (replacement possibility is protected by calibration seal). These parameters are displayed only for information
3. Parameters 23... 29 will be displayed only if the meter is completed with the mains supply module. It can be modified (changed) in "SET" and "INF" display modes
4. Displayed parameter values, for example. "1.00-2" are given in exponential form:

There: X.XX E XX

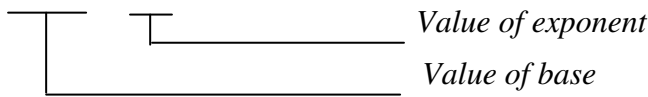

For example: value 1,25E-2 = 1,25*10⁻² = 0,00125.

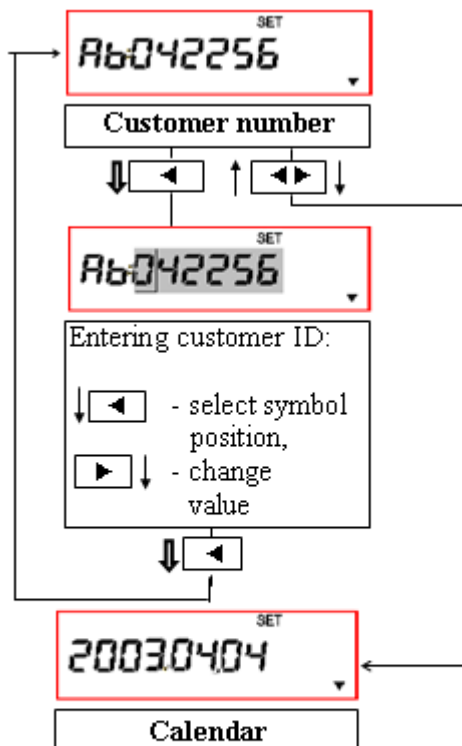

Fig. 7.2.
Setting up parameters
(for example, Customer number)

Parameters, listed in Table 7.1 should be set up as shown in Fig. 7.2:

Select the parameter to be modified, then press and hold button until parameter value starts blinking – alteration mode is entered.

Select required position by pressing button . Shortly pressing button , set the required value (or select from list). Save changes by holding button pressed and return to display mode.

7.2.2. Parameterization (configuration) procedure

Recommendations for the configuration change

Measurement circuits, energy calculation algorithms, type of the temperature sensors, value of pressure for thermal energy calculation and numbers of flow sensors should be checked according to individual heat meter data (see Paragraph 13).

If are required by measurement circuit, other parametres of a configuration should be made active and entered:

The additional flow inputs (V3 and V4) are activated, the inputs parameters values corresponding values of the water meters which will be connected to these inputs are set: pulse value, minimal and maximum flow rate, type of input pulses and the minimal possible pulse frequency period.

The additional pressure inputs are activated, the inputs parameters values corresponding values of the pressure sensors, which will be connected to these inputs are set: limits of current, minimal and maximum pressure orresponding to current limits.

The additional tempertature input (T3) are activated. If it is used on regulation mode „On2“ – it is obliged to make active the temperature measurement channel T3 for measurement of outdoor temperature.

The individual parameters for a pulse / frequency output should be selected from the list

The regulation function are activated, operating mode is selected from list, and the parameters values are entered.

If necessary a customer number is entered.

The communication interfaces settings are entered: M-bus adress, data transfer rate, parity.

Report printing language and communication with the printer interface type are selected from list

If necessary real time clock and calendar readings are corrected

The suggested next battery replacement date is set: (or current date plus 12 years for mains power supply version). Suggested battery replacement date is calculated by adding estimated battery operation time to the current date. Estimated battery operation time is given in the Table 7.1:

Table 7.1

Number of flow sensors powered from calculator battery	Battery operation time, years
-	10
1 (extra current to 35 mA)	8
2 (extra current to 70 mA)	6

Configuration of heat meter is possible via optical (or Wire) interface and in conjunction with the specific configuration programme.

7.3. Setting up jumpers

For battery supply:

If voltage 3,6 V from the pin “19” and “22” is used to power extra flow sensors V3 and V4, the jumper (beside terminal block) should be conjunct.

For mains supply:

If voltage 3,6 V from the pin “19” and “22” is used to power extra flow sensors V3 and V4, the jumper (beside terminal block) should be compulsory disjunct.

If the device is equipped with universal interface module (including M-bus, CL, RS-232 interfaces and two current or pulses outputs):

- M-bus, CL or RS-232 interface is activated by plugging in the jumpers “CL – M-bus – RS-232” in such way, that required interface type appears beside the terminal pins “46,,48”. Marking on the jumper board will show the functional description of the pins.
- required current limits of the 1-st and 2-nd current outputs are set by switching the jumpers “I1” and “I2” into one of the following positions: “0-5 mA”, “4-20 mA” or “0-20 mA”.
- required type of pulses output are set by switching the jumpers „+P1 +P2 GND“:
 - Galvanically isolated passive pulses outputs - not jumpers
 - Galvanically isolated active (+24 V) pulses- „GND“, “+P1” ir “+P2”

7.4. Optional modules. Exchanging of modules

Heat meter may be delivered with 230 V, 24 V power supply module or 3,6 V battery power supply and one of the external communication modules. Possible options are listed in the paragraph 3. Communication module types and specific application restrictions are described in the Table 7,2.

Table 7.2

Communication module type	Purpose, functions	Application restrictions
SKU45 Universal with two current outputs	User may choose one of three available interfaces (M-bus, CL, RS-232). Two current outputs are available, with user-selectable current limits (“4-20 mA” or “0-20 mA”).	Only for 230 V power supply
SKU46 Universal with two pulse outputs	User may choose one of three available interfaces (M-bus, CL, RS-232). Two pulse outputs are available, with user-selectable type - galvanically isolated passive pulses or not galvanically isolated active (+24V) pulses	Only for 230 V power supply
SKS43 M-bus	Allows connecting the device to M-bus network (up to 254 devices in parallel) in distance up to 2 km	Suitable for all power supply options
SKS48Y Special interface for connection to the controller Rubisafe-P01	Distance up to 5 m. Designed for direct connection to the controller Rubisafe-P01.	Suitable for all power supply options
SKS48 Special type, compatible with RS-232 interface	Distance up to 15 m. Designed to connect equipment with RS-232 interface, where RTS +9...+12 V and DTR -9...-12 V signals are used	Suitable for all power supply options
SKSRS485 RS485	Connecting to RS485	Only for 230 V power supply

Mains supply or battery module is in the bottom part of the calculator, on the right side beside the terminal block, while communication interface module is on the left side.

Modules can be exchanged on-site, by opening the lid, unscrewing the appropriate fixing bolt and pulling out the module from the connector.



! Disconnect the equipment from mains supply before replacing modules!

7.5. Verification of installation and set-up

After installing the heat meter, let measured fluid flow through the flow sensor, and switch on the power supply. Measured parameter values should be indicated on the display, if the heat meter (calculating unit, flow, pressure and temperature sensors) is installed correctly. If measured parameter values are not displayed correctly, it is necessary to verify the installation.

8. OPERATION

8.1. Control buttons

The information can be displayed using two control buttons  and  which are on the top of the calculator(see Fig. 8.1).

Configuration button “SET” is under the cover and it is protected by mounting seal (see Fig.). Clicking on this button you can activate configuration and fast verification modes.

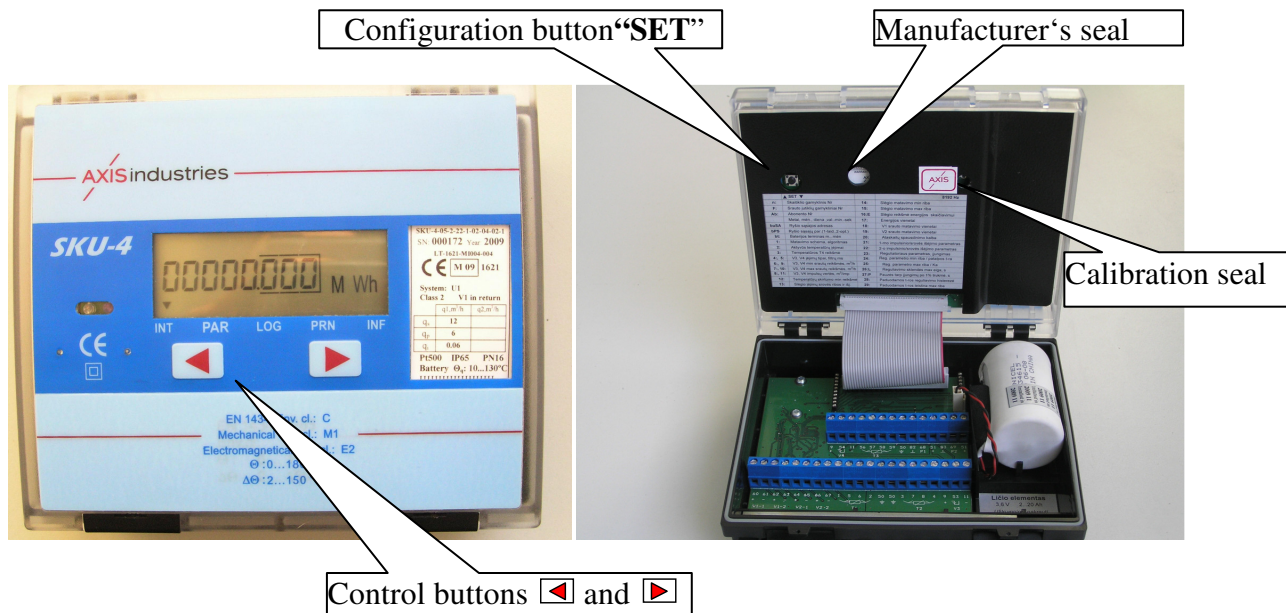

Fig. 8.1 Front of the calculator, cover closed, without seals and view at an open cover

8.2. Display function

The calculator is equipped with 8-digits LCD (Liquid Crystal Display) with special symbols to display parameters, measurement units and operation modes.

The following information can be displayed:

- integral and instantaneous measured parameters,
- archive data,
- device configuration information,
- report printing control information.

The display constantly shows the total thermal energy. Other data can be displayed sequentially using the control buttons.

Display description

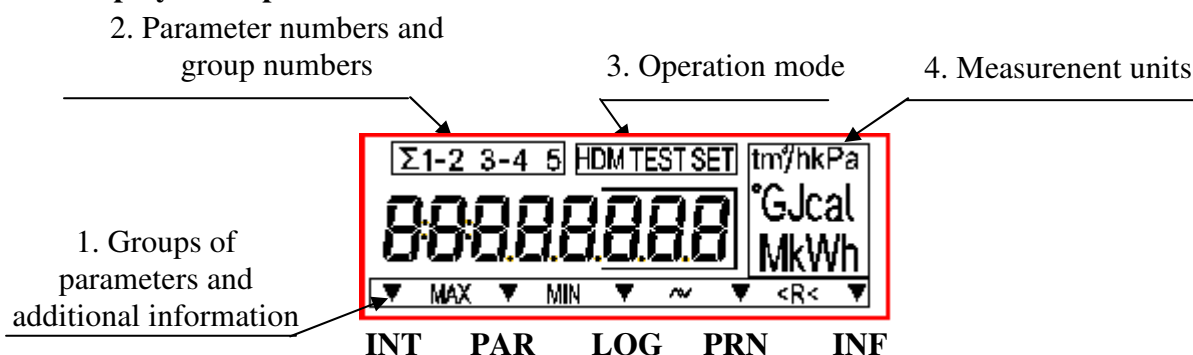

Key to symbols	Description
1. Groups of parameters	
▼	Group of displaying corresponding parameters (display level)
2. Number and group of indicated parameters	
1...5	Number of energy tariff or number of measurement channel (volume, flow, temperature, pressure)
1-2	Differences (difference of heating medium quantity (M1-M2), (V1-V2) or temperature difference (Θ1-Θ2))



3. Operation mode	
H	Hourly archive data is being printed (displayed)
D	Daily archive data is being printed (displayed)
M	monthly archive data is being printed (displayed)
TEST	Test mode
SET	Parameterization mode
3. Operation mode	
H	Hourly archive data is being printed (displayed)
D	Daily archive data is being printed (displayed)
M	monthly archive data is being printed (displayed)
TEST	Test mode
SET	Parameterization (configuration) mode
4. Measurement units	
m³(t)	Water volume (mass)
m³/h	Flow rate
kPa	Pressure
°C	Temperature, temperature difference
GJ, Gcal, MWh, kWh	Energy
kW	Power
h	Hours
5. Additional information	
R	Relay output is activated
R<	Parameter value exceeds maximum permissible value (for relay outputs)
<R	Parameter value is below minimum permissible value (for relay outputs)
^	Relay P1 is closed (increase)
v	Relay P2 is closed (decrease)
MIN	The minimum value
MAX	The maximum value

Menu structure

The display in user level is arranged in five levels (loops):

User levels	Identification symbols
1st level. Displaying integral parameters values	▼ INT PAR LOG PRN INF
2nd level. Displaying (viewing) instantaneous parameters values	▼ INT PAR LOG PRN INF
3rd level. Displaying (viewing) set day parameters and archive data values	▼ INT PAR LOG PRN INF
4th level. Printing reports by standard printer	▼ INT PAR LOG PRN INF
5th level. Displaying configuration settings and programming relay output parameters	▼ INT PAR LOG PRN INF

Press and hold (> 3 s) button  or button  to move to the next display level.

To view data in the same display level press shortly (< 3 s) buttons  or . The display will switch automatically to the highest level of displaying current values of integral parameters, or – if at least one error has been detected – error code will be displayed after 5 minutes of inactivity.

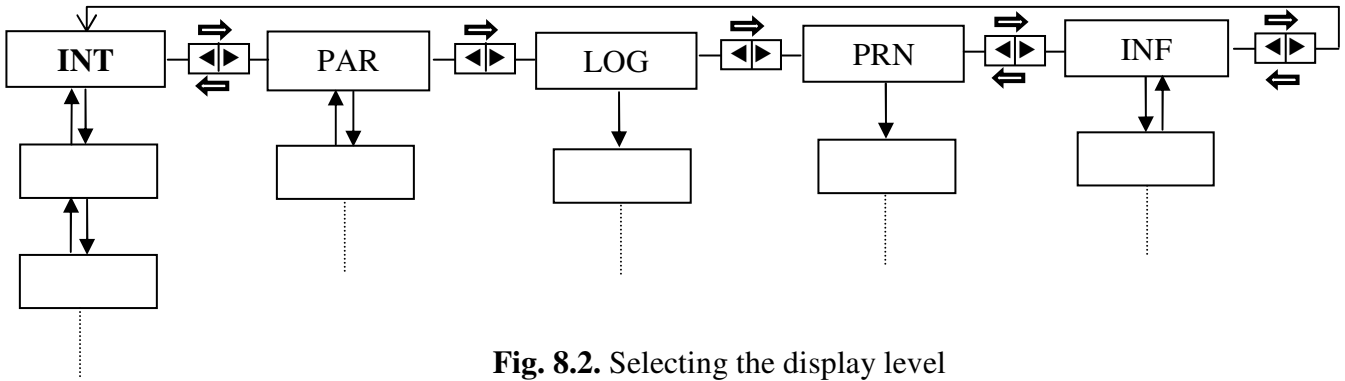

Fig. 8.2. Selecting the display level

Arbitrary symbols, used in the diagrams:

◀ - left button, ▶ - right button, ⇨ - long press (> 3 s) → - short press (< 3 s)

Additional mode	Identification symbols
7th level. Parameterization mode	SET ▼ ▼ ▼ ▼ ▼ INT BIL INF PRN LOG
8th level. Test mode	TEST ▼ ▼ ▼ ▼ ▼ INT BIL INF PRN LOG

At Service level it is provided two service modes:

6th level. Parameterization(configuration) mode (SET)	SET ▼ ▼ ▼ ▼ ▼ INT PAR LOG PRN INF
7th level. Test mode (TEST)	TEST ▼ ▼ ▼ ▼ ▼ INT PAR LOG PRN INF

To enter the parameterization (configuration) mode (6th level), open the lid and press “SET” button. Label “SET” is displayed in the upper right side of the display.

In this mode by means of control buttons or via optical interface, the use of personal computer with special software, you can change the configuration of the meter (see section 7.2).









By short pressing “SET” button you can leave the parameterization mode and enter to test mode (7th level).

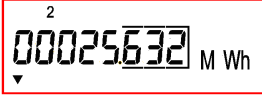

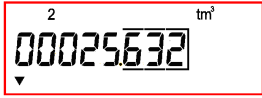
Press the “SET” button once to leave the test mode and confirm return to the 1st level.

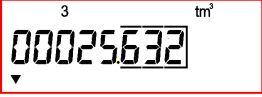
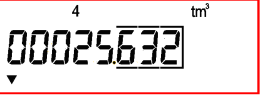
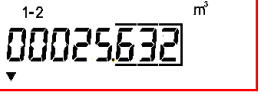
On Each level the list of displayed parameters may be reduced and the parameter listing order can be changed (on SET mode, using the computer with the special software, joining via the optical or wire communication interface) depending on the user requirements.



8.2.2. Displaying integral parameter values (level 1)

	Accumulated total energy ($\sum E$)
	Accumulated Energy component (E1)

	Accumulated Energy component (E2)
	Accumulated volume V1 or mass M1
	Accumulated volume V2 or mass M2
	Reverse flow fluid volume (mass) for 2-nd channel (winter/summer operation mode only)
	Accumulated volume V3 or mass M3
	Accumulated volume V4
	Differences of volume (V1—V2) or mass (M1-M2) Vandens kiekių (tūrio V1-V2 arba masės M1-M2) skirtumas
	Operating hours
	Operating hours without energy calculation error
	Significant fault (stopping energy calculation) code E1 In the case of the error - it is always displayed on the top
	Transistory fault code Er2

Parameter values are displayed in sequence, shortly pressing buttons:  - next parameter,  - previous parameter

Sequence of displayed parameters may vary depending on selected measurement scheme and number of installed sensors.

Press and hold (> 3 s) button  to move to the next display level(PAR), and button  to move to displsy level (INF).

The display will switch automatically to the highest level of displaying current values of integral parameters, or – if at least one error has been detected – error code will be displayed after 5 minutes of inactivity.

Error codes description

The meter continuously analyzes operational modes, diagnoses and informs of errors in system work

Significant faults Er¹

If significant faults Er¹ are detected in work of heating system, energy calculation is stopping and these errors are displayed via 6 character error code:

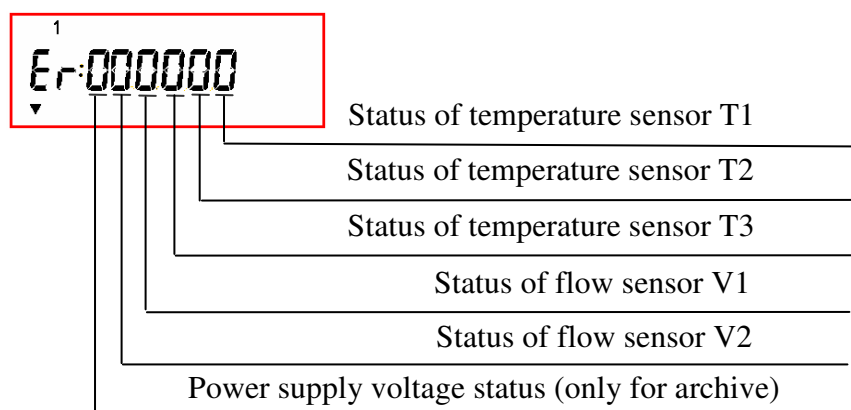

Detailed description of significant faults codes Er¹

Error display	Error description
Er1: 000000	No error. Normal mode
Er1: 000001	Fault in temperature Θ_1 measuring circuit*: temperature difference $\Theta_1 - \Theta_2 < d\Theta_{min}$ ($d\Theta_{min}$ – the minimum value of temperature difference)
Er1: 000002	Fault in temperature Θ_1 measuring circuit: temperature $\Theta_1 < 0$ °C (or sensor has short circuit)
Er1: 000004	Fault in temperature Θ_1 measuring circuit: temperature $\Theta_1 > 180$ °C (or sensor has open circuit)
Er1: 000010	Fault in temperature Θ_2 measuring circuit*: temperature difference $\Theta_1 - \Theta_2 < d\Theta_{min}$ ($d\Theta_{min}$ – the minimum value of temperature difference)
Er1: 000020	Fault in temperature Θ_2 measuring circuit**: temperature $\Theta_2 < 0$ °C (or sensor has short circuit)
Er1: 000040	Fault in temperature Θ_2 measuring circuit**: temperature $\Theta_2 > 180$ °C (or sensor has open circuit)
Er1: 000200	Fault in temperature Θ_3 measuring circuit**: temperature $\Theta_3 < 0$ °C (or sensor has short circuit)
Er1: 000400	Fault in temperature Θ_3 measuring circuit**: temperature $\Theta_3 > 180$ °C (or sensor has open circuit)
Er1: 002000	Fault in q1 measuring circuit*: flow rate $q_1 < q_{1i}$ (q_i – the minimum allowable value of flow rate)
Er1: 004000	Fault in q1 measuring circuit*: flow rate $q_1 > q_{1s}$ (q_s – the maximum allowable value of flow rate)
Er1: 008000	Fault in q2 measuring circuit: Fault in flow measuring channel
Er1: 020000	Fault in q2 measuring circuit *: flow rate $q_2 < q_{2i}$ (q_i – the minimum allowable value of flow rate)
Er1: 040000	Fault in q2 measuring circuit *: flow rate $q_2 > q_{2s}$ (q_s – the maximum allowable value of flow rate)
Er1: 080000	Fault in q2 measuring circuit: Fault in flow measuring channel
Er1: 100000	No supply voltage (only for data logger)
Note: * - only when non-standard energy calculation algorithm is applied	
** - only in cases where the temperature sensors T2, T3 are used to calculate the thermal energy	
Active error codes are added and simultaneously displayed	

Transistory fault Er²

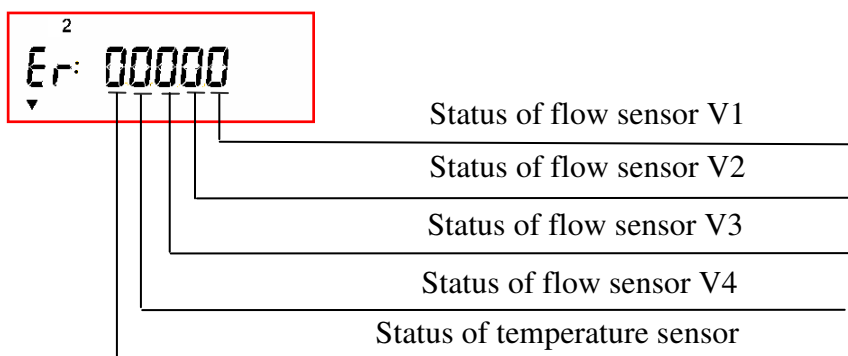

If transistory faults Er¹ are detected in work of heating system, energy calculation do not stop and these errors are displayed via 5 character error code:









Detailed description of transistory faults codes Er²

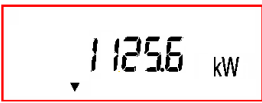
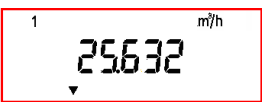
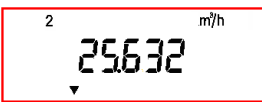
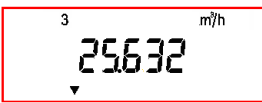
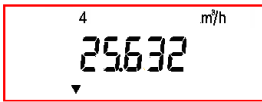

Display	Description
Er2: 00000	No error. Normal mode
Er2: 00001	Flow q1 flow in reverse direction
Er2: 00002	Flow value $q1 < q1_i$ (the minimum allowable value of flow rate)
Er2: 00004	Flow value $q1 > q1_s$ (the maximum allowable value of flow rate)
Er2: 00008	Flow sensor V1 is not filled by a liquid
Er2: 00010	Flow q2 flow in reverse direction *
Er2: 00020	Flow value $q2 < q2_i$ (the minimum allowable value of flow rate)
Er2: 00040	Flow value $q2 > q2_s$ (the maximum allowable value of flow rate)
Er2: 00080	Flow sensor V2 is not filled by a liquid
Er2: 00100	Srauto įėjime V3 ilgiau nei 24 val. nėra impulsų**
Er2: 00200	Flow value $q3 < q3_i$ (the minimum allowable value of flow rate)
Er2: 00400	Flow value $q3 > q3_s$ (the maximum allowable value of flow rate)
Er2: 00800	Short circuit V3 ***
Er2: 01000	On input V4 more than 24 hours do not arrive pulses **
Er2: 02000	Flow value $q4 < q4_i$ (the minimum allowable value of flow rate)
Er2: 04000	Flow value $q4 > q4_s$ (the maximum allowable value of flow rate)
Er2: 08000	Short circuit V4***
Er2:10000	Temperature difference $\Theta1 - \Theta2 < d\Theta_{min}$
Er2:20000	Temperature difference $\Theta1 - \Theta2 < 0^\circ C$
Er2:40000	Temperature $\Theta3 < -40^\circ C$ or sensor has short circuit ****
Er2:80000	Temperature $\Theta3 > 180^\circ C$ or sensor has open circuit ****
Er2:50000	At the same time there are two error: "10000" and "40000"
Er2:60000	At the same time there are two error: "20000" and "40000"
Er2:90000	At the same time there are two error: "10000" and "80000"
Er2:A0000	At the same time there are two error: "20000" and "80000"
<p>Pastabos: * - Are not shown, when the algorithm 'winter / summer' is applied ** - only when flow input type "L" is on ("24 hours pulse control") *** - only when flow input type "E" is on ("short circuit control") **** - only when temperature measurement channel T3 is on Active error codes are added and simultaneously displayed</p>	

8.2.3. Displaying (viewing) instantaneous (informative) parameters values (level 2)

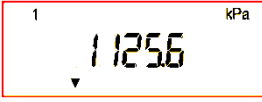
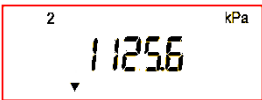
Parameter values are displayed in sequence, shortly pressing buttons:  - next parameter,  - previous parameter

	Thermal power
	Flow rate q1. Negative flow rate is marked with minus (-) in the display (measurement units - m ³ /h or t/h)
	Flow rate q2. Negative flow rate is marked with minus (-) in the display (measurement units - m ³ /h or t/h)
	Flow rate q3
	Flow rate q4
	Measured fluid temperature Θ1
	Measured fluid temperature Θ2
	Measured fluid temperature Θ3
	Preset temperature Θ4
	Measured temperature difference Θ1-Θ2
	Measured fluid pressure p1
	Measured fluid pressure p2

Sequence of displayed parameters may vary depending on selected measurement circuit and Sequence of displayed parameters may vary depending on selected measurement scheme and number of active sensors.

Press and hold (> 3 s) button  to move to the next display level (LOG), and button  to move to display level (INF).

The display will switch automatically to the highest level of displaying current values of integral parameters, or – if at least one error has been detected – error code will be displayed after 5 minutes of inactivity.

8.2.4. Displaying (viewing) set day parameters values and archive data values (level 3)

8.2.4.1. When set day and archive data viewing mode (“LOG”) is entered (and set day function is active), set day time stamp value (The date format is <day>.<month>.<year>) will be displayed in turn with relevant parameter value (accumulated energy value) :

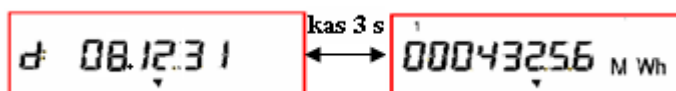

By shortly pressing button you can select parameter value for viewing.

By shortly pressing button you can select for viewing previous set day parameters values (previous months or previous years data depends on configuration of calculator)

To display archive data (see p.8.2.4.2) press and hold button .

If a set day function is inactive - archive data review mode (p.8.2.4.2) will be displayed immediately when you enter to level „LOG“.

8.2.4.2 When archive data viewing mode is entered, time stamp value will be displayed:



(The date format is <hour> <day>.<month>) in turn with relevant parameter value and parameter group ID (in three seconds interval). For example, alteration of E1 during 19-th of January, 13-th hour:

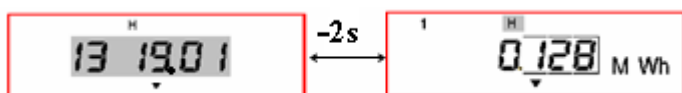

Press and hold button while time is displayed to select required time interval: date is displayed, and first character starts blinking (it is possible to select required time interval now). Move cursor (blinking character) in closed circle by shortly pressing button . Alterate selected value by shortly pressing button . Confirm the selection and return to previous display level by holding down button .

Select parameter group by shortly pressing button while parameter is displayed (display zone D):

H – hourly values increase; average hourly pressure and temperature values group with registered error and error occurrence time,

D – daily values increase; average daily pressure and temperature values group with registered error and error occurrence time,

M – monthly values increase; average monthly pressure and temperature values group with registered error and error occurrence time,

[no symbol] – group of absolute parameter values at the real time point.

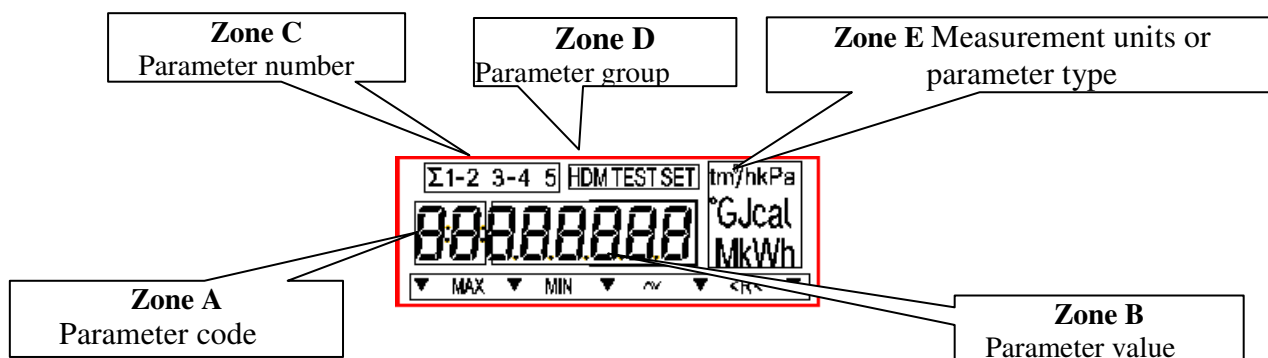

Shortly pressing button  while parameter is displayed will allow to select desired time point or interval. List of parameters is presented in the Table 8:

Table 8

Symbol on the upper part of display (Zone C)	Measurement unit (parameter symbol) Zone E	Parameter code Zone A	Parameter value Zone B
Σ	MWh (Gcal, GJ)	-	Total thermal energy E
2	MWh (Gcal, GJ)	-	Thermal energy component E1
3	MWh (Gcal, GJ)	-	Thermal energy component E3
1	t (m3)	-	Fluid mass (volume) M1 (V1)
2	t (m3)	-	Fluid mass (volume) M2 (V2)
-2	t (m3)	-	Reverse flow fluid mass (volume) -M2 (V2)
1-2	t (m ³)	-	Fluid mass (volume) difference M1-M2 (V1-V2)
3	t (m3)	-	Fluid mass (volume) M3 (V3)
4	t (m3)	-	Fluid volume V4
1	°C	-	Average (hourly, daily or monthly) temperature Θ_1
2	°C	-	Average (hourly, daily or monthly) temperature Θ_2
3	°C	-	Average (hourly, daily or monthly) temperature Θ_3
1	kPa	-	Average (hourly, daily or monthly) pressure p1
2	kPa	-	Average (hourly, daily or monthly) pressure p2
1		Er:	Error code Er1 (total sum)
2		Er:	Error code Er2 (total sum)
	h		Device run-time
	h	A:	Operating hours (without energy calculation error)
1-2	h	1:	Time, when temperature difference ($\Theta_1 - \Theta_2$) < d Θ_{min}
1	h	2:	Time, when flow rate $q_1 < q_{1min}$
2	h	2:	Time, when flow rate $q_2 < q_{2min}$
3	h	2:	Time, when flow rate $q_3 < q_{3min}$
4	h	2:	Time, when flow rate $q_4 < q_{4min}$
1	h	4:	Time, when flow rate $q_1 > q_{1max}$
2	h	4:	Time, when flow rate $q_2 > q_{2max}$
3	h	4:	Time, when flow rate $q_3 > q_{3max}$
4	h	4:	Time, when flow rate $q_4 > q_{4max}$
2	h	8:	Failure time of flow measurement channel V2
3	h	8:	Failure time of flow sensor V3
4	h	8:	Failure time of flow sensor V4

To move to the next level - “PRN” - press and hold button .

8.2.5. Printing reports (level 4)

Connect printer to calculator using external communication interface or optical communication adapter. Printer serial port data transfer rate should be the same as defined in calculator settings. Printer should be set to condensed printing mode.

For printing report via wire interface – in configuration parameter “20” – to set value “1”, for printing via optical interface – to set value “2” (see table 7.1)

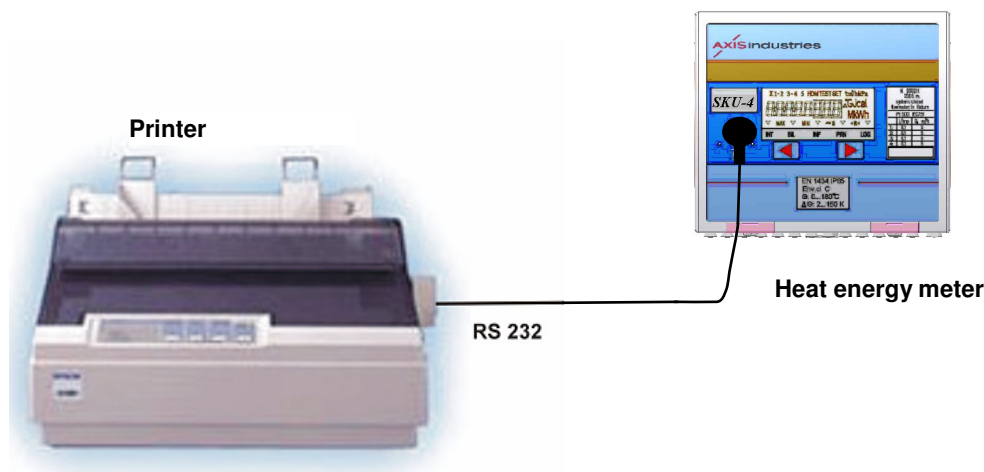

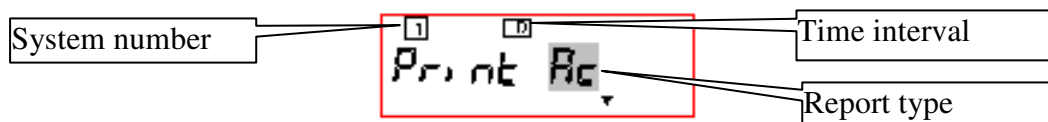





Fig. 8.3. Connection of printer via optical interface

To enter report printing mode, press and hold button  several times, until label “PRN” is reached. LCD will display the following:



Select blinking LCD zone (report type, time interval or heating system number) by shortly pressing button . Define the following report options by shortly pressing button :

Key to symbols	Description
Report type	
Ac	Printing summary report
rP	Printing monthly set day parameter values
In	Printing current values of integral parameters
CF	Printing device parameterization parameters
RL	Printing current parameter values
Time interval	
H	Printing hourly parameter values
D	Printing daily parameter values
M	Printing monthly parameter values
System number	
1	Printing report for heating system
2	Printing report for additional water meters

Holding down button  will allow to select report starting date and time. LCD displays (h mm.dd):

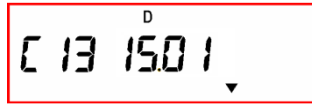

Starting date and time should be defined. First character starts blinking. Press button to move to another character (selected character starts blinking). Required value can be set by shortly pressing button . For hourly report starting hour, day and month should be defined. For daily report – starting day and month, for monthly report – only starting month should be defined.

Holding down button stores the selection, and report ending date selection mode will be activated. LCD displays (h mm.dd) :



Report ending date and time is defined in the same way as describe above.

Printing will start after holding down button one more time. While report is being printed, blinking label “Print” will be displayed. Printing can be paused and started again (for example, to add paper) by shortly pressing button . If printing is paused, label “Print” will stop blinking.

To move to another menu level press and hold button .

Press and hold button to stop printing in any time.

8.2.6. Displaying configuration settings and programming relay output parameters (5 lygis)

Displaying configuration settings

Sequence of displayed parameters may vary depending on selected measurement scheme and number of active sensors.

Settings also are shown, how is indicated in the Table 7.1, only are not shown an inscription the SET. Foe example:





Parameter values are displayed in sequence, shortly pressing buttons: - next parameter, - previous parameter





Use configuration data viewing mode “INF” to view device configuration settings (programmed parameters and operation modes) and – if regulation function is activated – to change relay output parameter values.

8.3. Programming relay output parameters in regulation mode

8.3.1. Configuration parameters with codes “23:” ..”29:” (Table 7.1) are dedicated for programming relay output parameters. When information data inspection mode “INF” is entered, it is possible to activate or deactivate regulation function, also to choose regulated parameter and control relay output manually by shortly pressing buttons or and selecting the parameter “23:”.

When button is pressed for long time, regulation status symbol “On” or “Off” starts blinking. Shortly pressing button will activate “On1” , “On2”, or deactivate “Off” regulation function.

When the operation mode On1 is entered, shortly pressing button  will activate regulated parameter selection mode (parameter will start blinking). Select regulated parameter code (see Table 7.1) by shortly pressing button .

If regulation mode is deactivated (“Off”), it is possible to control the regulated valve manually. Shortly press button  - symbol “R” starts blinking. Pressing button  will start closing the valve – symbol “vR” will be displayed. Pressing button  one more time will start opening the valve – symbol “^R” will be displayed. Pressing button  once again will switch off valve control – only symbol “R” will be displayed.

8.3.2. Programming relay output parameters in regulation mode On1

At work in this mode the regulator can maintain temperature in the established limits, forbid value of temperature to exceed an admissible maximum limit, forbid value of temperature to fall below an admissible minimum limit or to form alarm signal at occurrence of such disturbances.

According to the procedure described in Section 7.1, if necessary, it is possible to change the upper limit of regulation parameter (setting code “25:”) or lower limit of regulation parameter (setting “24:”), full travel time for actuator valves (setting code “26:L”) and the speed of regulation – pause time in seconds between the valve opening (closing) of 1% of the full valve runtime (setting code “27:P”).

If value of parameter “27:P” is established equal to zero - at break of conditions the corresponding relay will be continuously connected (it can be used for alarm signal formation).

To move to menu level (“INT”) press and hold button .

8.3.3. Programming relay output parameters in regulation mode On2

This mode of regulation is designed for automatic control of temperature T1 for maintenance of the room temperature (setting "24"), depending on the changing of the outdoor temperature (measured by temperature sensor T3) and of adaptation factor value of building (setting "24").

Recommended value of parameter „25:“ is 15.

Settings "26", "27" set as in the mode On1 (see p. 8.3.2)

Only for mode On2 is used:

- parameter „28:“ - for maintenance of accuracy of flow temperature (hysteresis). Recommended value of maintenance accuracy is 0,5...1 °C (Reducing its value, frequency of opening/closing of the valve increases)

- parameter „29:“ - for setting of the maximum admissible limit of flow temperature
Recommended value is 10 ... 20 ° C greater than the possible maximum working flow temperature.

This parameter is intended to limit the flow temperature at failure of temperature sensor or erroneous settings case.

8.4. Activating test mode

In test mode it is possible to achieve precise results within short measuring time.

When test mode is activated, calculation process is stopped and the meter readings are saved in memory. After return to normal mode, the original values from before the test are displayed again.

Test mode is activated by short double pressing configuration button „SET“. “TEST” label is displayed on the upper part of LCD.

In test mode by shortly pressing button , you can select required parameter:

Energy ΣE
Energy E1
Energy E2
Volume V1
Volume V2 (module)

VolumeV3
VolumeV4
Mass M1
Mass M2 (module)
Masè M3
Number of pulses N3
Number of pulses N4
Temperature Θ 1
Temperature Θ 2
Temperature difference Θ 2
Temperature Θ 3
Thermal power P
Pressure p1
Pressure p2

Volume of liquid can be simulated automatically by the calculator,

Provides automatic verification mode (For definition of measurement error of energy, without measurement error of flow), when the meter is simulating water quantity and calculate the quantities of energy, according to the measured temperature (and pressure).

The automatic test mode can be used, when flow sensors are not connected or not filled by water. Testing time is 100s.

Shortly pressing the button  will imitate flow pulses: V1 = 100000, V2 = 50000, V3 = 100000, V4 = 100000 (in volume units, displayed on LCD)

During the test, blinking label „TEST“ will be displayed.

After the 100 s label “TEST” will stop blinking. Shortly pressing the button  you can read test results.

8.5. Remote data reading

For data transmission from meter it can be used optical interface (The optical head is placed on the front panel of the calculator, as shown in fig.8.3 and is connected to RS-232 interface of reading device) or any other wire serial interface, depending on the interface module is completed (see Table 7.2) can be used.

Data collection from meters can be realised via PC, via telephone modem, via GSM modem, via Internet, and so on.

The scheme of meter connection to the computer is presented in Annex B, Fig. F4. Modem or printer connection scheme – in Annex B, Fig.B5.

Restriction of operating time (only for battery supply version):

-operating time after forced activation with any control button not more than 5 min.

-total time of sending and receiving data per month not more than 80 min (interface is blocked after declime of time limit. It can be unblocked after forced activation with any control button not more than for 5 min).

9. VERIFICATION

Metrological control of heat meter parameters is performed according to requirements defined in EN 1434-5.

10. TRANSPORTATION AND STORAGE REQUIREMENTS

Requirements for safe transportation and storage of temperature and pressure sensors are provided in relevant technical documentation.

Packed equipment may be transported in any type of covered vehicle. Equipment should be anchored reliably to avoid shock and possibility to shift inside vehicle.

Equipment should be protected against mechanical damage and shock.

Equipment should be stored in dry, heated premises, where environment temperature is not lower than +5 °C. No aggressive chemical substances should be stored together because of corrosion hazard.

11. WARRANTY

Manufacturer gives the warranty that equipment parameters will meet the technical requirements, listed in the paragraph 2 of this document, if transportation, storage and operation conditions will be followed.

Waranty period - 12 months from bringing into operation, but not more than 18 months from manufacturing date.

Manufacturer's address:

AB "Axis Industries ", Kulautuvos g. 45a, Kaunas LT-47190, Lithuania
tel. +370 37 360234; fax. +370 37 360358.

12. INDIVIDUAL DATA

Serial number of meter		
Code of type of measurement circuit		
Accuracy class	2	
Flow sensors data:	1	2
Serial number		
Maximum flow rate q_s , m ³ /h		
Permanant flow rate q_p , m ³ /h		
Minimum flow rate q_i , m ³ /h		
Nominal pressure PN, MPa	1,6	1,6
Temperature sensors type	Pt500	
Value of pressure, for calculation enthalpy		
Energy measurement units		
Power supply type	Battery; 230VAC	
Temperature sensors conection method	2-wire, 4-wire	

Annex A

Measurement schemes and energy calculation formulas

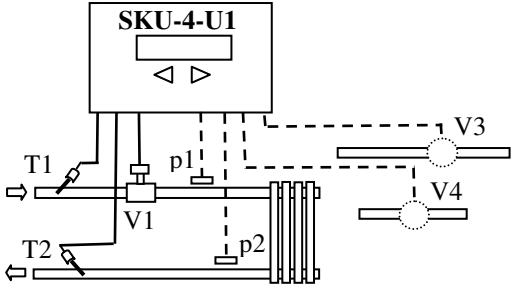
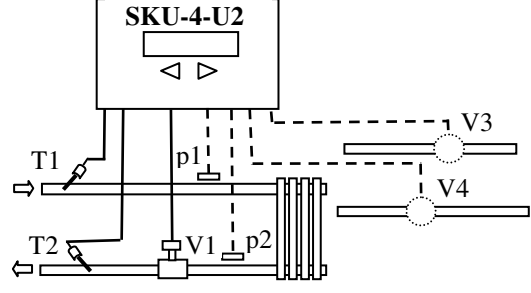
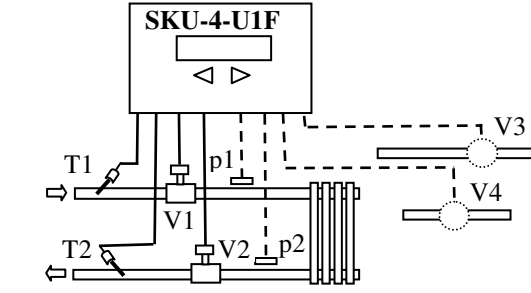
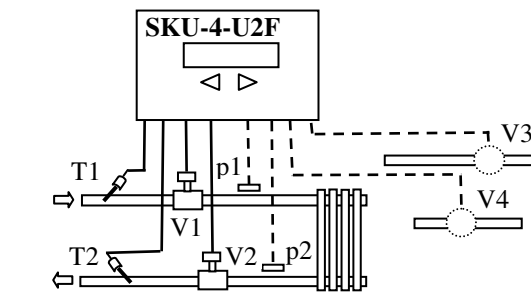
Application type	Energy calculation formula
For closed heating/cooling systems	
<p>U1 - Meter for heating. Flow sensor in flow pipe</p> 	$E = V1 \cdot \rho_1 \cdot (h_{T1} - h_{T2})$ $M1 = V1 \cdot \rho_1$
<p>U2 - Meter for heating. Flow sensor in return pipe</p> 	$E = V1 \cdot \rho_2 \cdot (h_{T1} - h_{T2})$ $M1 = V1 \cdot \rho_2$
<p>UIF - Meter for heating with leakage detection option The flow sensor in flow pipe</p> 	$E = V1 \cdot \rho_1 \cdot (h_{T1} - h_{T2})$ $M1 = V1 \cdot \rho_1$ $M2 = V2 \cdot \rho_2$
<p>U2F - Meter for heating with liquid leakage detection option. The flow sensor in return pipe</p> 	$E = V2 \cdot \rho_2 \cdot (h_{T1} - h_{T2})$ $M1 = V1 \cdot \rho_1$ $M2 = V2 \cdot \rho_2$

Annex A

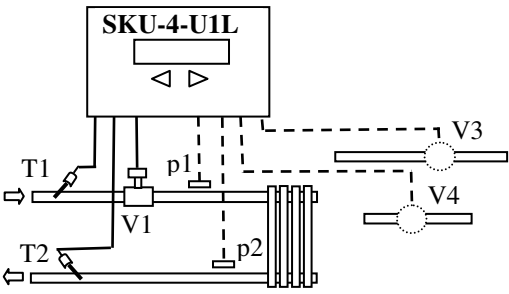
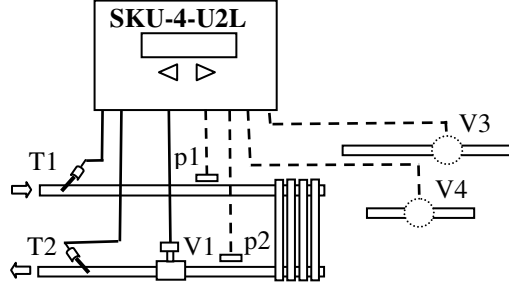
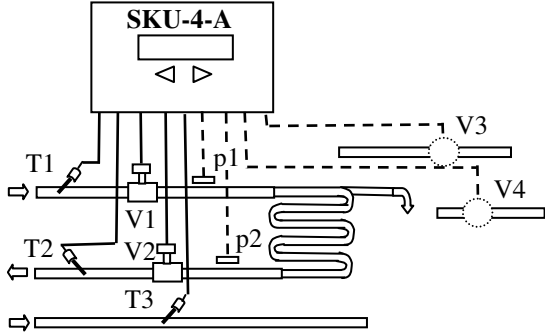
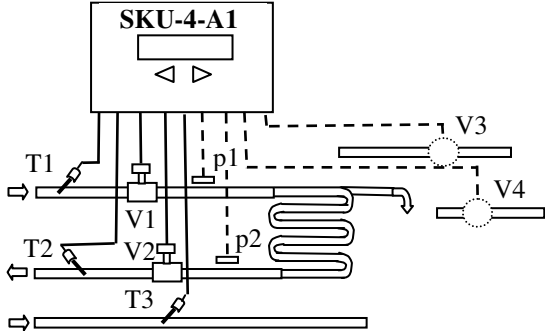
Application type	Energy calculation formula
For closed heating/cooling systems	
<p>U1L – Meter for heating and cooling. The flow sensor in flow pipe</p> 	$\sum E = E1 + E2$ <p>than $\Theta1 > \Theta2$: $E1 = V1 \cdot \rho_1 \cdot (h_{T1} - h_{T2})$, $E2 = 0$</p> <p>than $\Theta1 < \Theta2$: $E2 = V1 \cdot \rho_1 \cdot (h_{T2} - h_{T1})$, $E1 = 0$</p> $M1 = V1 \cdot \rho_1$
<p>U2L - Meter for heating and cooling. The flow sensor in return pipe</p> 	$\sum E = E1 + E2$ <p>than $\Theta1 > \Theta2$: $E1 = V1 \cdot \rho_2 \cdot (h_{T1} - h_{T2})$, $E2 = 0$</p> <p>than $\Theta1 < \Theta2$: $E2 = V1 \cdot \rho_2 \cdot (h_{T2} - h_{T1})$, $E1 = 0$</p> $M1 = V1 \cdot \rho_2$
For closed or opens heating systems	
<p>A - Meter for heating with the cold water temperature measurement</p> 	$\sum E = E1 - E2$ $E1 = V1 \cdot \rho_1 \cdot (h_{T1} - h_{T3})$ $E2 = V2 \cdot \rho_2 \cdot (h_{T2} - h_{T3})$ $M1 = V1 \cdot \rho_1$ $M2 = V2 \cdot \rho_2$
<p>A1 – For accounting total energy and energy components for heating and hot water preparation with the cold water temperature measurement</p> 	$\sum E = E1 + E2$ $E1 = V2 \cdot \rho_2 \cdot (h_{T1} - h_{T2})$ $E2 = (V1 \cdot \rho_1 - V2 \cdot \rho_2) \cdot (h_{T1} - h_{T3})$ $M1 = V1 \cdot \rho_1$ $M2 = V2 \cdot \rho_2$

Annex A

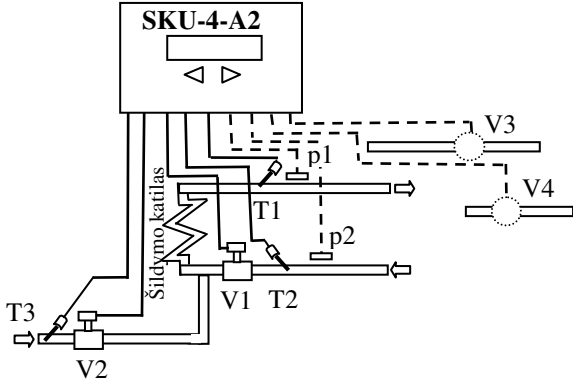
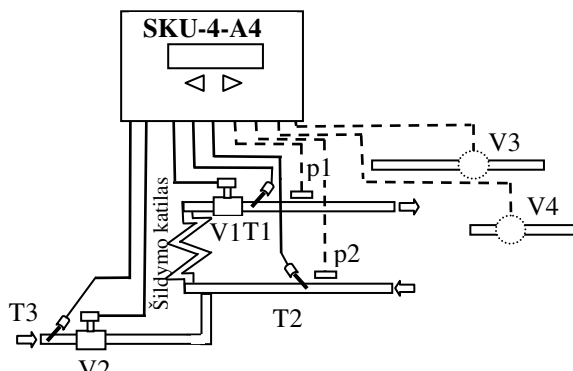
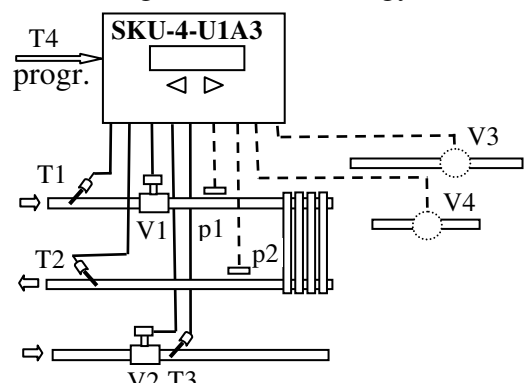
Application type	Energy calculation formula
For closed or open heating systems	
<p>A2 – For accounting of supplied heat energy. Flow sensors in return and replenishment pipes</p> 	$\sum E = E1 + E2$ $E1 = V1 \cdot \rho_2 \cdot (h_{T1} - h_{T2})$ $E2 = V2 \cdot \rho_3 \cdot (h_{T1} - h_{T3})$ $M1 = V1 \cdot \rho_2$ $M2 = V2 \cdot \rho_3$
<p>A4 – For accounting of supplied heat energy. Flow sensors in flow and replenishment pipes</p> 	$\sum E = E1 + E2$ $E1 = (V1 \cdot \rho_1 - V2 \cdot \rho_3) \cdot (h_{T1} - h_{T2})$ $E2 = V2 \cdot \rho_3 \cdot (h_{T1} - h_{T3})$ $M1 = V1 \cdot \rho_1$ $M2 = V2 \cdot \rho_3$
For combined heating - hot-water preparing systems	
<p>U1A3- Two independent heat meters: 1st - For closed heating system. Flow sensor in flow pipe. 2nd - For accounting of hot water energy</p> 	$\sum E = E1 + E2$ $E1 = V1 \cdot \rho_1 \cdot (h_{T1} - h_{T2})$ $E2 = V2 \cdot \rho_3 \cdot (h_{T3} - h_{T4})$ $M1 = V1 \cdot \rho_1$ $M2 = V2 \cdot \rho_3$

Annex A

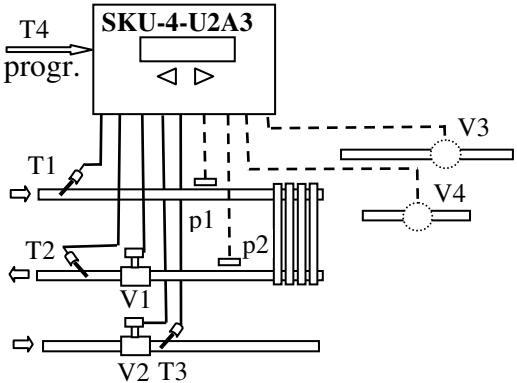
Application type	Energy calculation formula
For combined heating - hot-water preparing systems	
<p>U2A3- Two independent heat meters: 1st - For closed heating system. Flow sensor in return pipe. 2nd - For accounting of hot water energy</p> 	$\Sigma E = E1 + E2$ $E1 = V1 \cdot \rho_2 \cdot (h_{T1} - h_{T2})$ $E2 = V2 \cdot \rho_3 \cdot (h_{T3} - h_{T4})$ $M1 = V1 \cdot \rho_2$ $M2 = V2 \cdot \rho_3$
<p>Therein: ΣE, $E1$, $E2$ - The measured total energy and separate components of energy $V1...V3$ - The measured values of volume of a liquid $M1...M3$ - The calculated values of mass of liquid (For 1... 3 measuring channels) $\Theta1... \Theta2$ - The measured values of temperature $h_{T1}...h_{T3}$ - The enthalpies, according to water temperatures $\Theta1$, $\Theta2$, $\Theta3$ and corresponding to values of pressure (depending on the preset values) h_{T4} - The enthalpy, calculated according to water temperature $\Theta4$ (or preset temperature value $T4$) and corresponding to value of pressure (depending on the preset value) $\rho1... \rho3$ - Water densities, according to water temperatures $\Theta1$, $\Theta3$ and corresponding to values of pressure (depending on the preset value)</p>	

Annex B

Electrical wiring diagrams

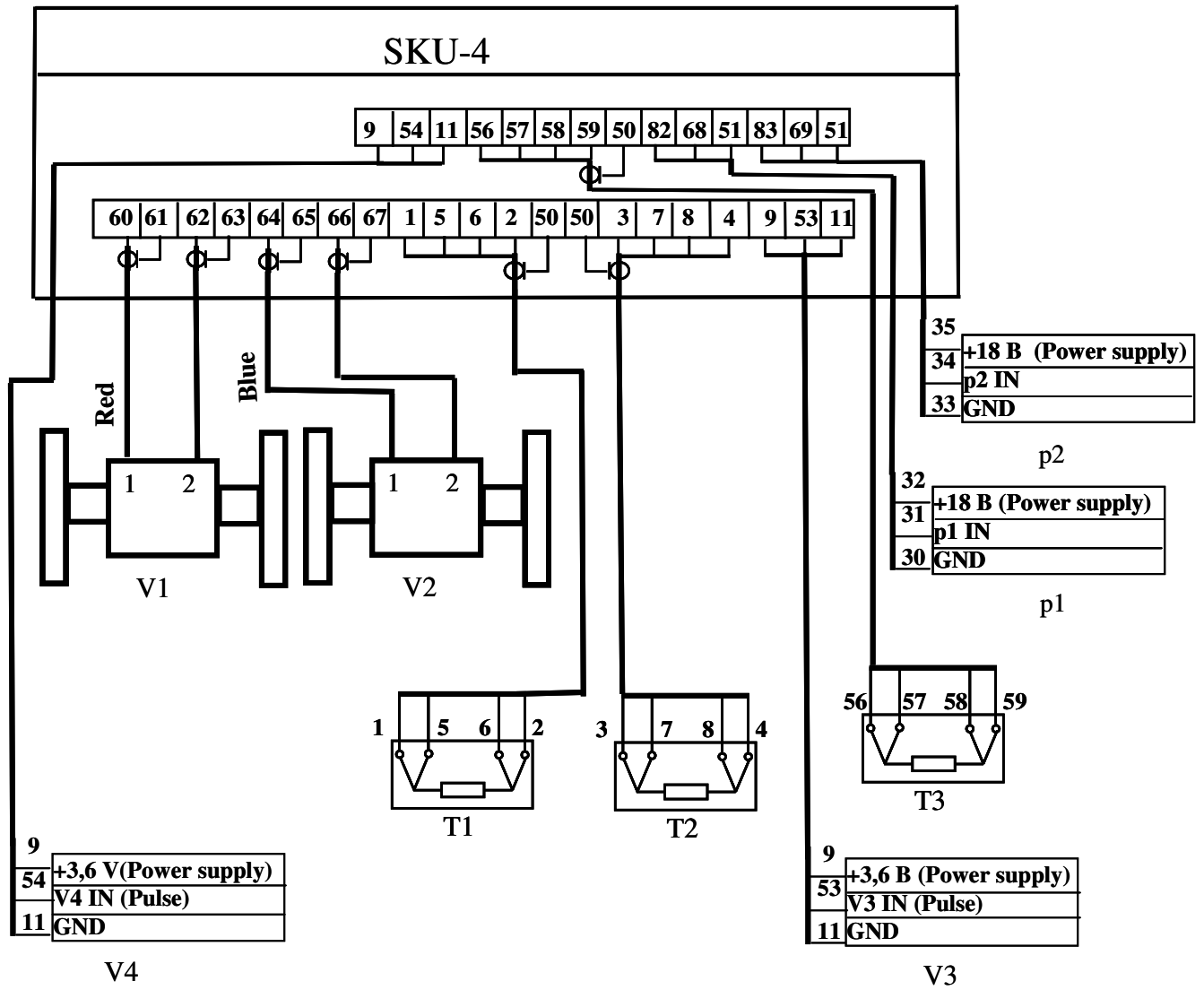

Fig. B1. Electrical wiring diagram
Temperature sensors with 4-wire connection

- T1 ... T3 - temperature sensors
- V1 ... V2 - ultrasonic flow sensors
- V3... V4 – water meters with pulse output
- p1 ... p2 -pressure sensors

Remark: 1. Only required for selected measurement scheme sensors should be connected (see Annex A)

Annex B

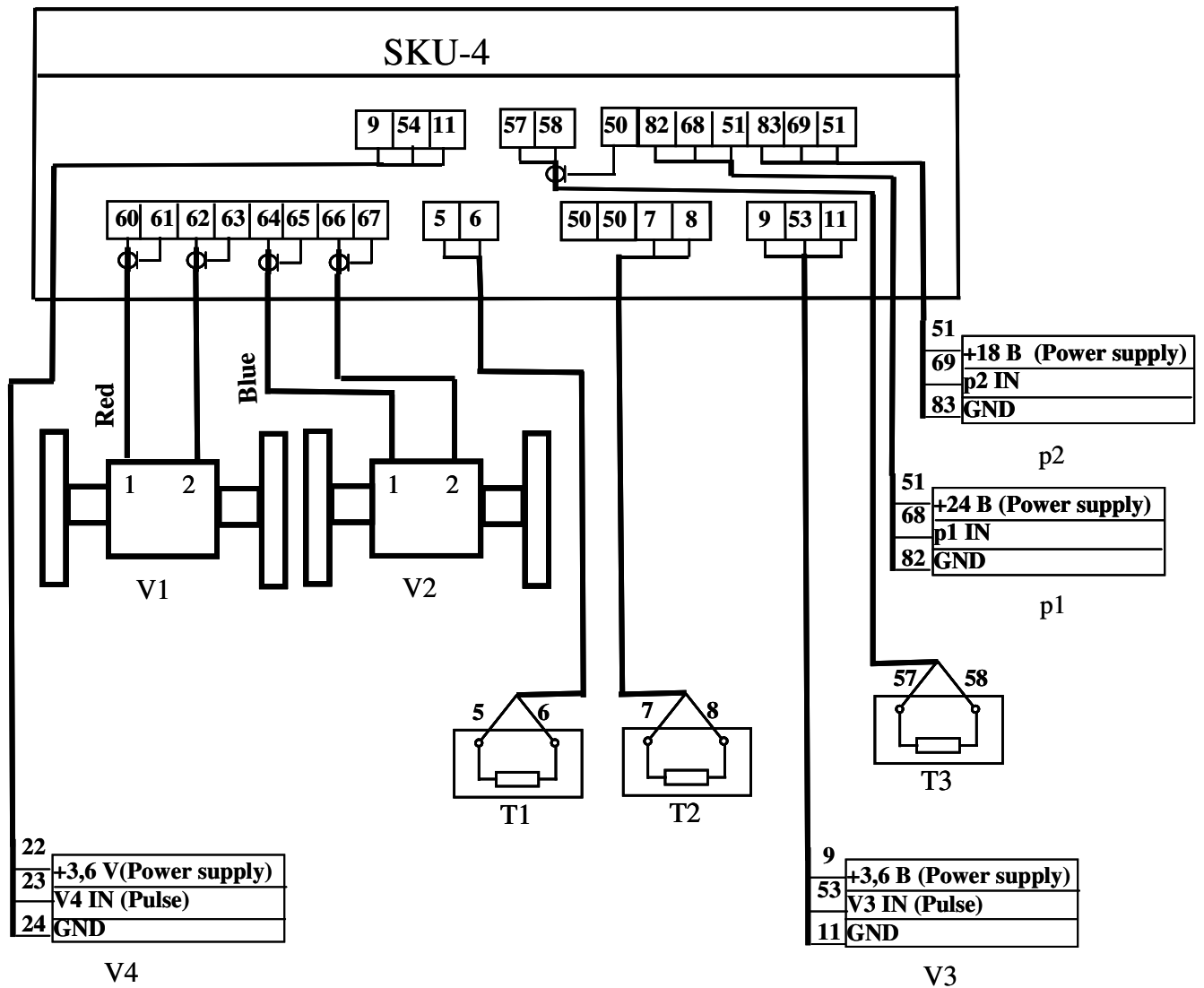

Fig. B2. Electrical wiring diagram
Temperature sensors with 2-wire connection

T1 ... T3 - temperature sensors
 V1 ... V2 - ultrasonic flow sensors
 V3... V4 – water meters with pulse output
 p1 ... p2 -pressure sensors

Remark: 1. Only required for selected measurement scheme sensors should be connected (see Annex A)

Annex B

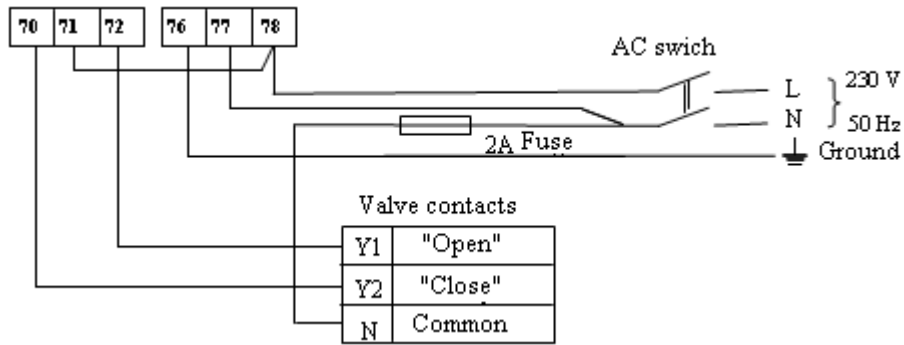

Fig. B3. Wiring diagrams for connecting of the meter to the line voltage 230 V and for connecting of the regulating valve. Valve power supply and meter supply is 230 V

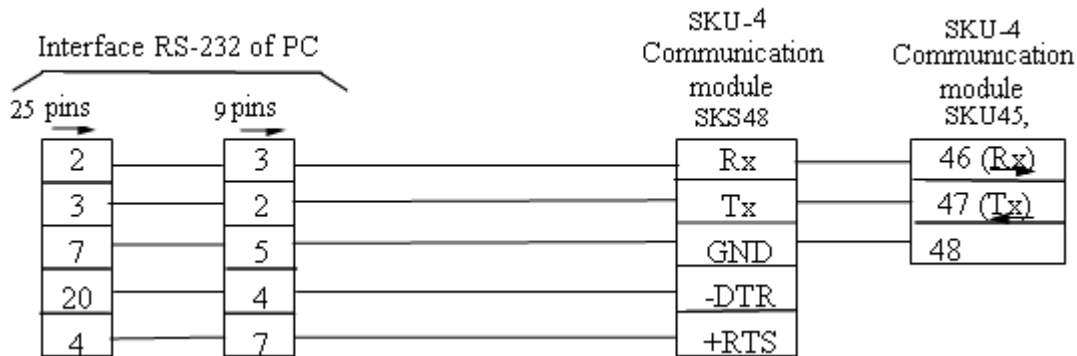

Fig. B4. Direct connection of the meter to the computer interface RS-232

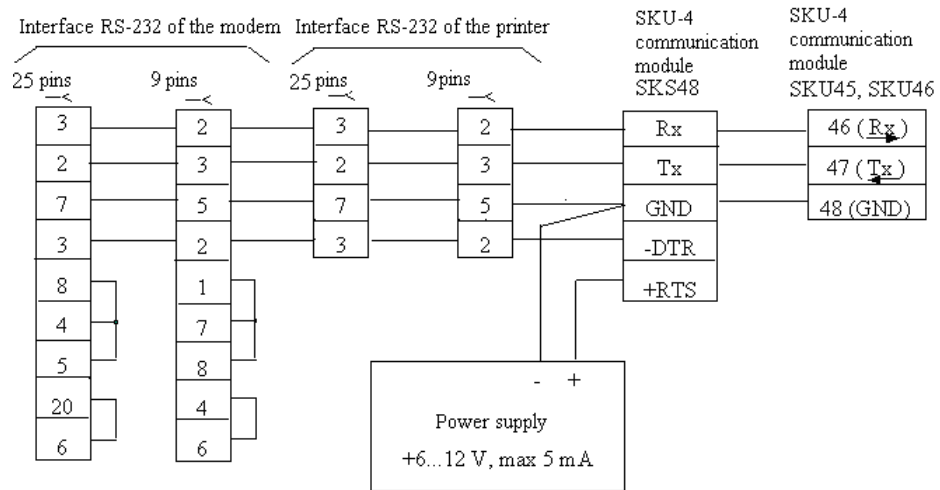

Fig. B5 Direct connection of the meter to the modem or printer via interface RS-232

Annex C Table C1. Numbering of terminals

Terminal number	Marking	Signal description
60	V1-1 (+)	Output signal (OUT) from 1st flow sensor V1 (ultrasonic sensor 1)
61	V1-1 (-)	GND for output (OUT) of 1st flow sensor V1 (ultrasonic sensor 1)
62	V1-2 (+)	Input signal (IN) from 1st flow sensor V1 (ultrasonic sensor 2)
63	V1-2 (-)	GND for input (IN) of 1st flow sensor V1 (ultrasonic sensor 2)
64	V2-1 (+)	Output signal (OUT) from 2nd flow sensor V2 (ultrasonic sensor 1)
65	V2-1 (-)	GND for output (OUT) of 2nd flow sensor V2 (ultrasonic sensor 1)
66	V2-2 (+)	Input signal (IN) from 2nd flow sensor V2 (ultrasonic sensor 2)
67	V2-2 (-)	GND for input (IN) of 2nd flow sensor V2 (ultrasonic sensor 2)
1*	T1	Current terminal for 1-st temperature sensor "+I"
5	T1	Voltage terminal for 1-st temperature sensor "+U"
6	T1	Voltage terminal for 1-st temperature sensor "-U"
2*	T1	Current terminal for 1-st temperature sensor "-I"
50*	\perp	GND for temperature sensors
3*	T2	Current terminal for 2-nd temperature sensor "+I"
7	T2	Voltage terminal for 2-nd temperature sensor "+U"
8	T2	Voltage terminal for 2-nd temperature sensor "-U"
4*	T2	Current terminal for 2-nd temperature sensor "-I"
9	+	+3,6V power supply voltage for flow sensor V3 , V4
53	V3	Pulse input signal from 3-rd flow sensor (IN)
11	\perp	GND for 3-rd and 4-th flow sensors
54	V4	Pulse input signal from 4-th flow sensor (IN)
56*	T3	Current terminal for 3-rd temperature sensor "+I"
57	T3	Voltage terminal for 3-rd temperature sensor "+U"
58	T3	Voltage terminal for 3-rd temperature sensor "-U"
59*	T3	Current terminal for 3-rd temperature sensor "-I"
82	\perp	GND for pressure sensor p1
68	P1	Input signal from 1-st pressure sensor (IN)
51	+	+18 V power supply voltage for pressure sensors p1, p2
83	\perp	GND for pressure sensor p2
69	P2	Input signal from 2-nd pressure sensor (IN)
REMARK: * - only for 4-wire connection method of temperature sensors (K)		

Table C2. Numbering of additional module terminals

Terminal number	Marking	Signal description
Numbering of power supply module terminals		
70	∨	Relay output “decrease”
71	R	GND for relay output
72	^	Relay output “increase”
76	⊥	Main ground
77	230V	Mains power supply (230V AC)
78	230V	Mains power supply (230V AC)
Numbering of communication module terminals		
76	⊥	GND for currency outputs (module SKS-45)
77	Iout1	1st currency outputs (+) (module SKU45)
78	Iout2	2nd currency outputs (+) (module SKU45)
79	⊥	GND for pulse outputs (module SKS-46)
80	Puls 1	1st pulse outputs (+) (module SKU46)
81	Puls 2	2nd pulse outputs (+) (module SKU46)
24 (73)	BUS	M-bus line L1(CL – CL1 or RS-232 – Rx (input))
25 (74)	BUS	M-bus line L2(CL – CL2 or RS-232 – Tx (output))
75	BUS	GND for communication interface RS-232

Annex D

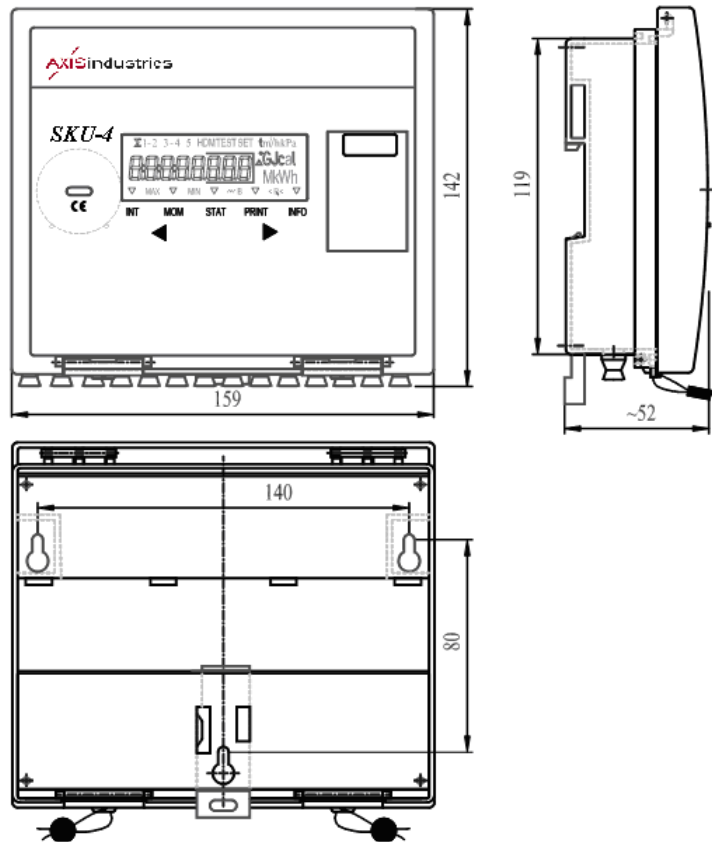
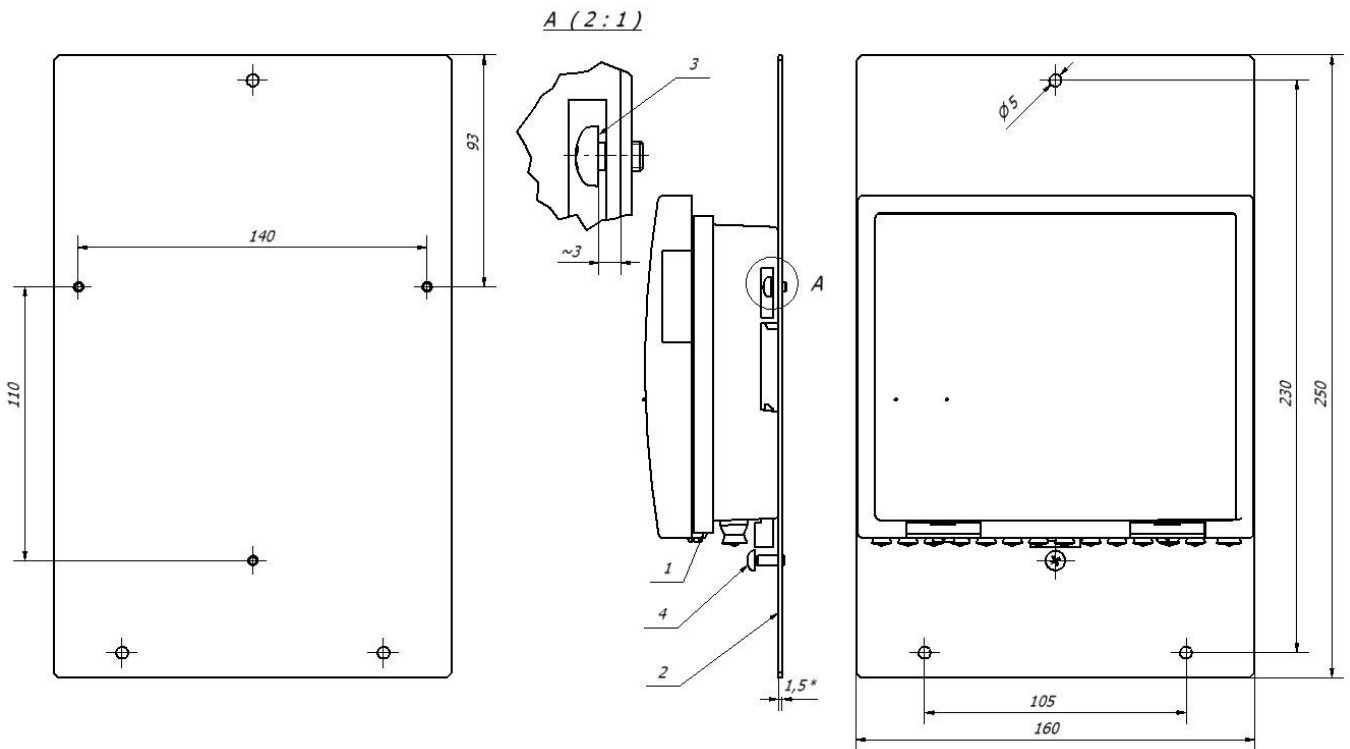

Fig.D1. Mounting dimensions of calculator



D1.1. Adapter plate according to figure 8 of EN1434-2:2007 for wall mounting of calculator

It can be used for wall mounting, if the aperture in the wall is too large for the calculator

- 1 – calculator SKU-4
- 2 – adapter plate
- 3 – screw M4x6
- 4 – screw M4x12

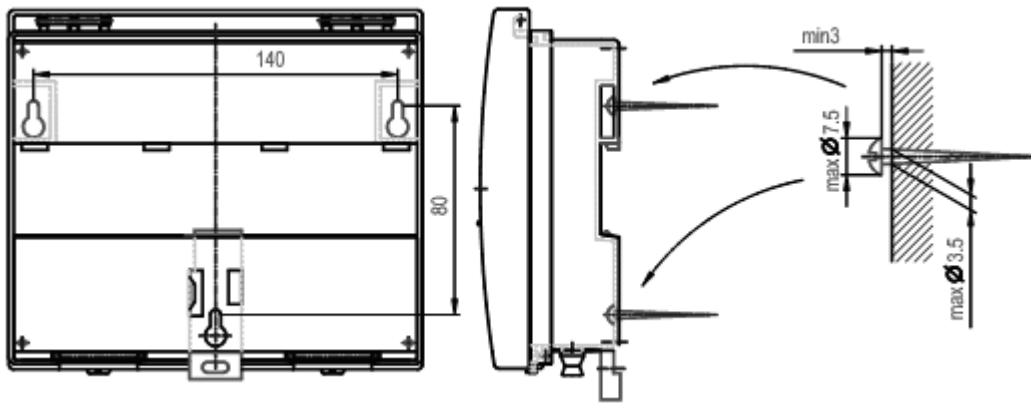

Fig. D2. Wall mounting, without possibility sealing of mounting

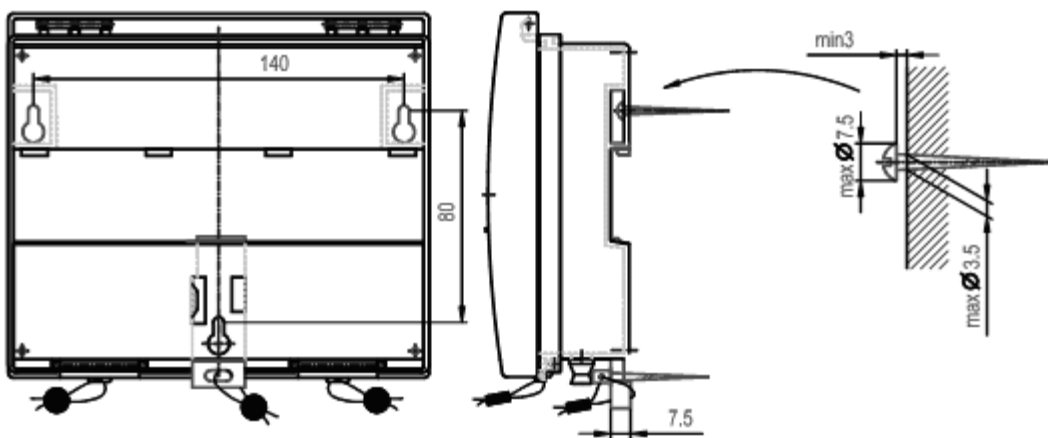
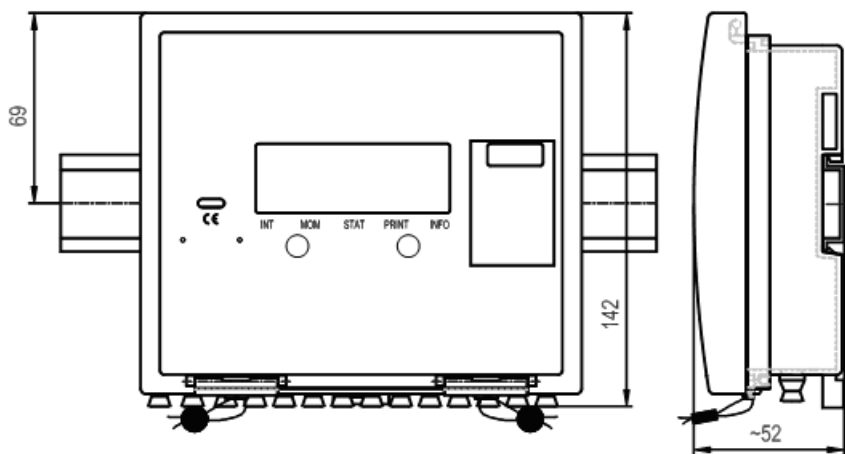

Fig. D3. Wall mounting, with possibility sealing of mounting

Annex D



D4. Mounting on standard DIN-rail

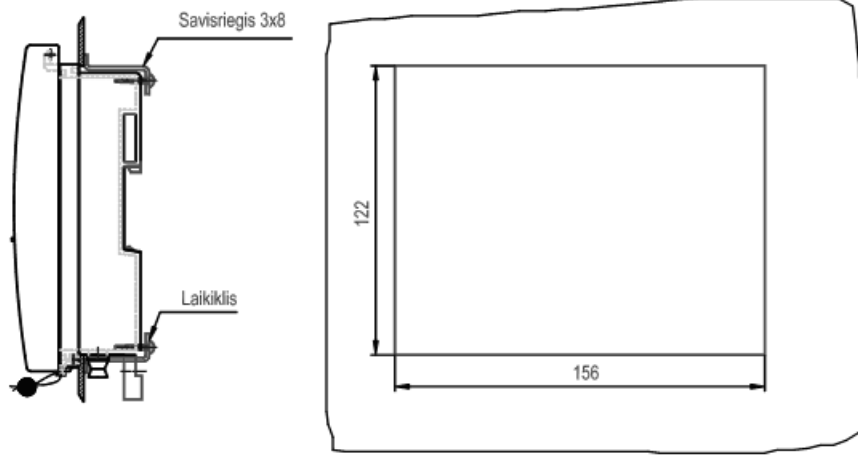
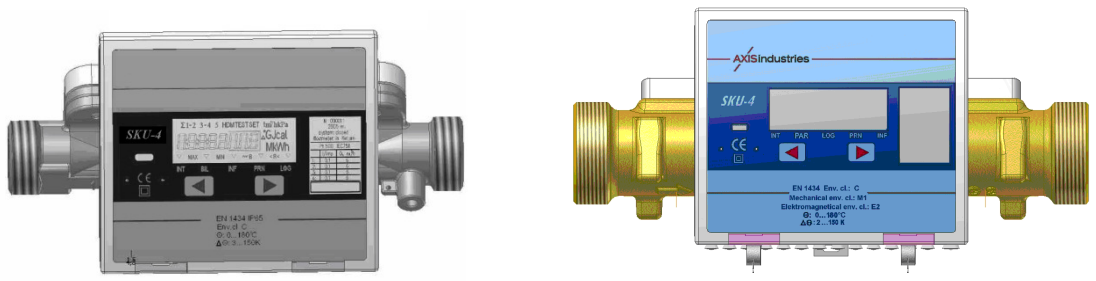
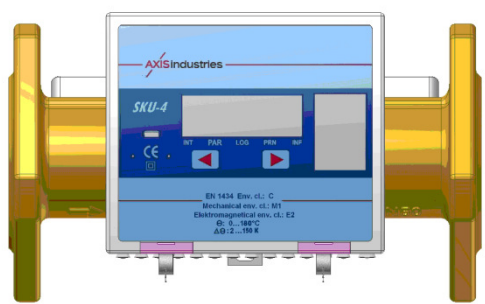

Fig.D5. Panel mounting



a) G 1 ¼ (qp = 3,5 m3/h; qp = 6,0 m3/h)

b) G 2 (qp = 10,0 m3/h)



c) DN 50 (qp = 15,0 m3/h)

Fig. D6. Mounting on ultrasonic flow sensor
Flow temperature max. 90 °C

Annex E

Sizes and dimensions of ultrasonic flow sensors

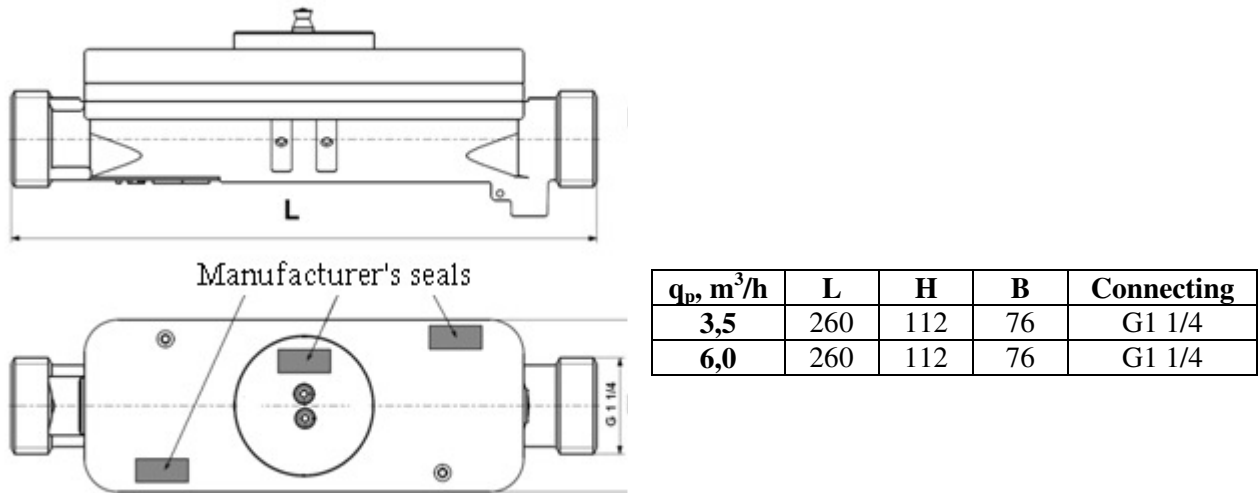

Fig. E1. Dimensions of flow sensors, $q_p = 3,5/6 \text{ m}^3/\text{h}$.

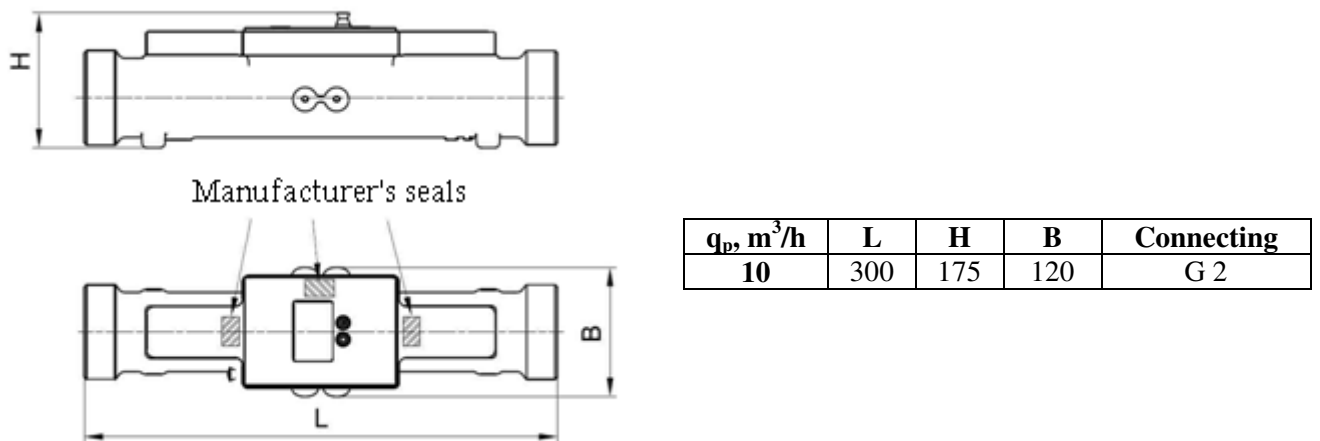

Fig. E2. Dimensions of flow sensors, $q_p = 10 \text{ m}^3/\text{h}$

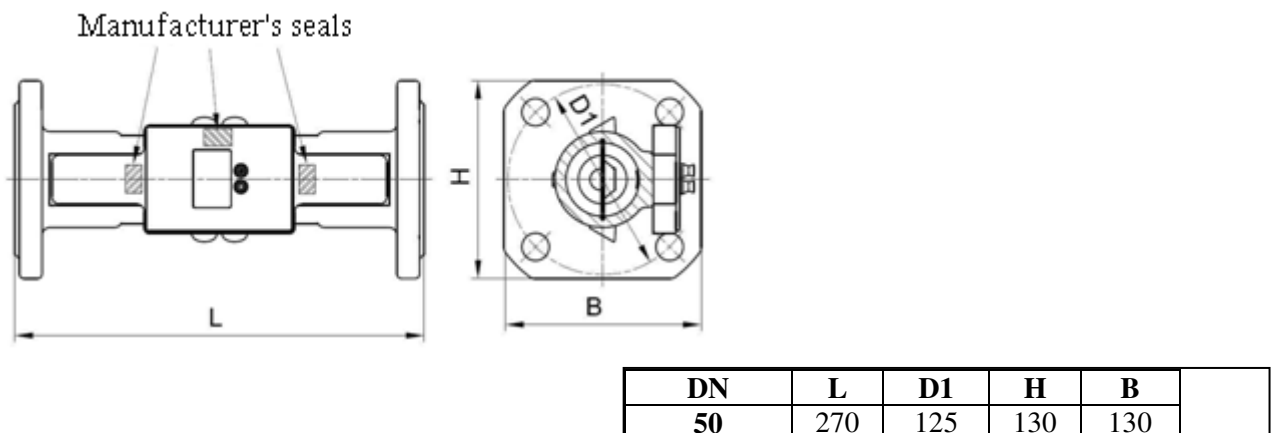
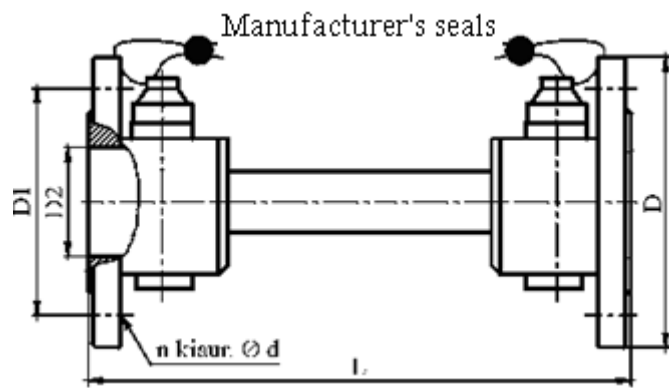

Fig. E3 Dimensions of flow sensors, $q_p = 15 \text{ m}^3/\text{h}$



$q_p, \text{ m}^3/\text{h}$	L	D	D1	D2	n	d
25	300	180	145	68.8	4	18
40	350	195	160	80.5	4	18
80	350	215	180	100	4	18

Fig. E4 . Dimensions of flow sensors, $q_p = 25/40/60 \text{ m}^3/\text{h}$

Annex F

Installation recommendation and sealing of temperature sensors

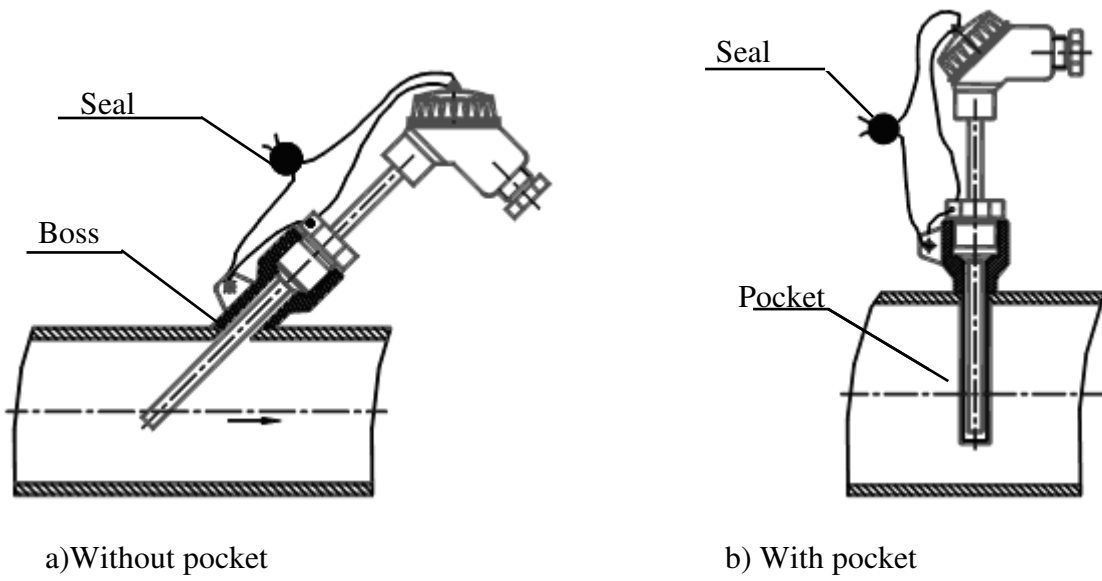

Fig.F1. Installation recommendations for temperature sensors with mounting head

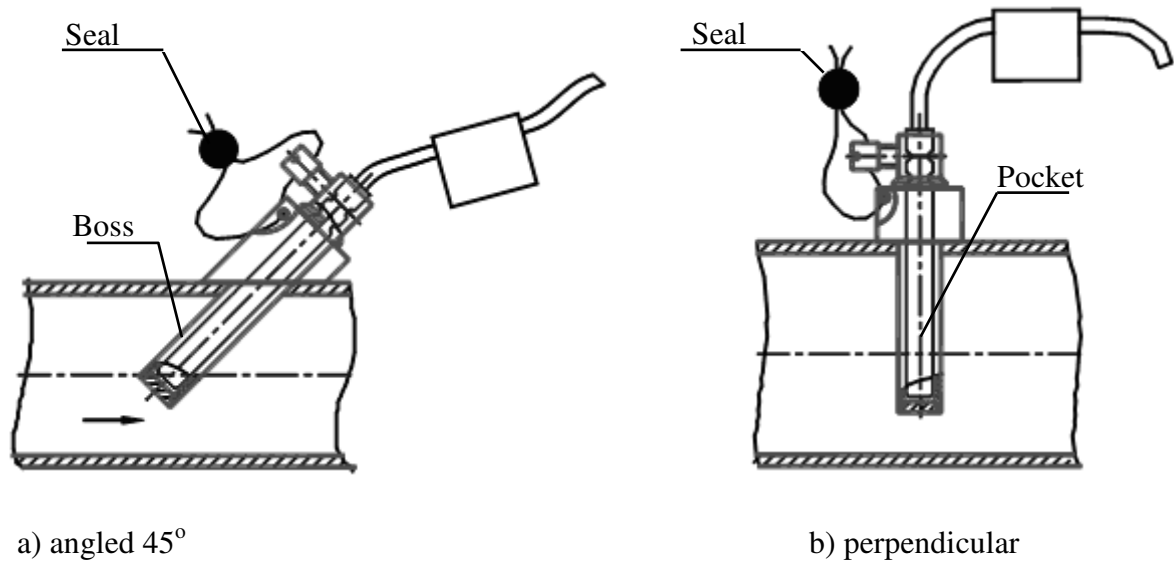
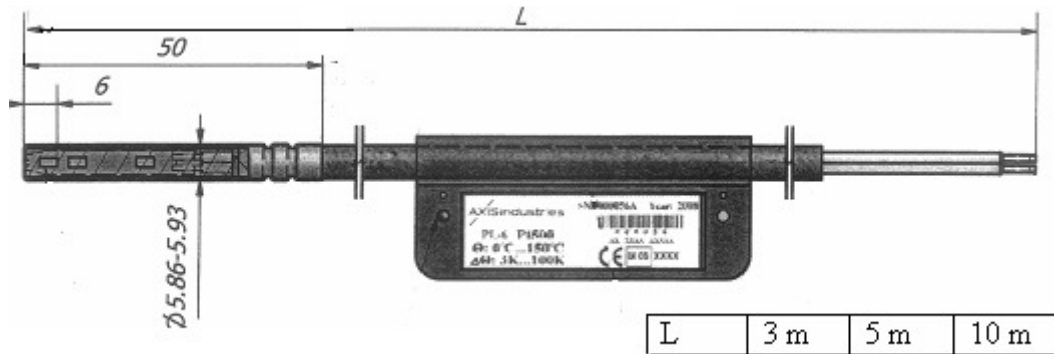
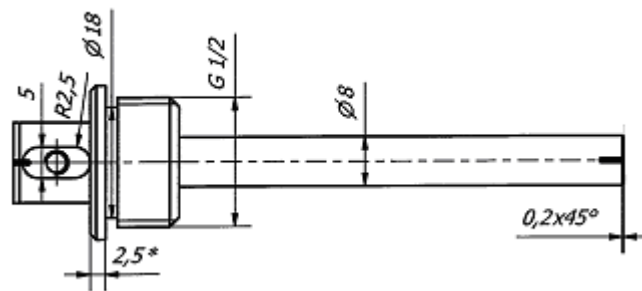

Fig.F2. Installation recommendations for temperature sensors with permanently connected signal leads

Annex F



- a) Temperature sensors with permanently connected signal leads
L- signal leads length



Nominal diameter of pipe, mm	DN20...DN100	DN125...DN150
Total length of pocket L, mm	100	135

- b) Temperature sensors pocket

F3 pav. Dimensions of temperature sensors type PL-6 and theirs pockets